

VacuumTables.com

Precision Holddown And Flotation Tables For All Industrial Applications

Vacuum TableS
Vacuum MotorS
AccessorieS
Complete airflow systemS
Engineered and Built
to Your SpecificationS



VacuumTables.com

A Division of Graphic Parts International Inc.

Manufactured by



The quality and integrity of G.P.I. Vacuum Tables are the result of over thirty years experience in vacuum table construction

Quality

Manufactured to meet the exacting needs of many industries worldwide, our precision engineered vacuum tables meet or exceed OEM requirements for smoothness, flatness and durability. They have become an essential tool for sensitive holddown applications where surface flatness is critical. Built to withstand long-term use, G.P.I. vacuum tables consistently perform at the level you demand.

Customization

Custom built to your specifications, G.P.I. vacuum tables are available in a variety of configurations to suit most any need. The all-aluminum construction employs a sandwich design for a superior strength-to weight ratio, using the thickest top and bottom plates in the industry for added durability.

On the surface, there are many options to choose from including anodized aluminum, stainless-steel and phenolic tabletops for sensitive materials and non-conductive applications. Disappearing registration guides, threaded inserts, cutouts and lift pins are among the more frequently requested options, and no one integrates them as seamlessly as we do. Inside our tables, you'll find an aluminum honeycomb core that is the cornerstone of our advanced airflow design. Our systems offer uniform airflow from edge to edge, as well as options for zoned airflow and more. Connection ports are positioned for your convenience, with maximum productivity and easy access in mind.

At G.P.I., we're all about making systems to fit your needs, and that's why we offer the range of options we do.

Vacuum tables from G.P.I. are manufactured to meet or exceed all OEM specifications for smooth, flat, long lasting production

Advantages

- Non-warping, Stay Flat™ technology
- Custom manufactured to your specifications
- Thickest gauge plate in the industry
- Proprietary fabrication process
- Honeycomb core for maximum airflow
- Sandwich design for superior strength-to- weight ratio
- Unsurpassed finish quality
- Uniform airflow from edge to edge
- Rust free, non-oxidizing, anti-static
- Fits all manufacturers, foreign and domestic

Options

- Cut outs
- Lift pins
- Side or bottom ports
- Disappearing guides
- Stainless steel surface

VacuumTables.com

A Division of Graphic Parts International Inc.

4321 North Knox Avenue • Chicago, Illinois 60641 USA
773.725.4900 • Fax: 773.777.0909
sales@vacuumtables.com • www.vacuumtables.com

VacuumTables.com

Table of contents

Vacuum Tables

Advanced Airflow Management	4
Design and Application Options	5-9
Airflow Vacuum Holddown & Blowback Systems	10-11
Airflow Adjustment	12
Flanges	13
Hose Connectors	13
Manifolds	13
Heavy-duty Vacuum Hoses - Clamps	14
Vacuum Table Rebuilding	14
Specialty Designs and Applications	15

Vacuum Motors

Max-Air™ Series of Vacuum Motors	16
Overview	17

Max-Air Models:

GPI-VM32-150	18
Performance Data	19
GPI-VM48-150	20
Performance Data	21
GPI-VM64-150	22
Performance Data	23
GPI-VM80-300	24
Performance Data	25
GPI-VM96-300	26
Performance Data	27
GPI-VM112-300	28
Performance Data	29
GPI-VM128-300	30
Performance Data	31
GPI-VM144-300	32
Performance Data	33

Options & Accessories

Vacuum Relief Valves	34-35
In-line Filters	36
Fittings	36
Specifications - Options & Accessories	37-39

On the cover:

Vacuum Table with Six-zone Airflow • Advanced Airflow Management, Page 4



Advanced Airflow Management



Six-zone table

Airflow Control SystemS

Designed for use with flat substrates, 3D components and parts, these reliable systems handle sensitive materials like glass and acrylics with the respect they deserve. In turn, scratching of the substrate is virtually eliminated as it is removed from the vacuum table. We also have the technology to help eliminate the troublesome "dimpling" on thin materials.

Determining the right amount of vacuum force needed to adequately hold a substrate or component in place involves the control of many variables. Blower size, air hose size, port placement,

substrate thickness, vacuum hole size and weight all need to be considered when designing a hold-down/flotation system. Substrate volatility, material handling requirements and other factors also contribute to the list of engineering and manufacturing considerations.

With extensive experience in addressing a variety of manufacturing concerns, we're all about making systems to fit your needs. That's why we offer a range of blowback options to lift and float your stock off the table on a bed of air. Manual systems with lever-activated release still fit the needs

of some operators, while automatic holddowns with foot pedal release are among today's more popular choices. Whatever your application criteria, our staff of airflow specialists will develop a system to meet your requirements. For superior holddown power with the safety you need, the latest in airflow technology is built into every table we make.

Developed over the course of three decades, our holddown and flotation systems deliver the perfect balance of vacuum suction and blowback timing necessary for safe and effective material handling.

Vacuum tables

Design and application options

Our 30-plus years of experience in vacuum table construction has always been guided by the same goal:

To build the flattest,
highest-quality vacuum table possible.

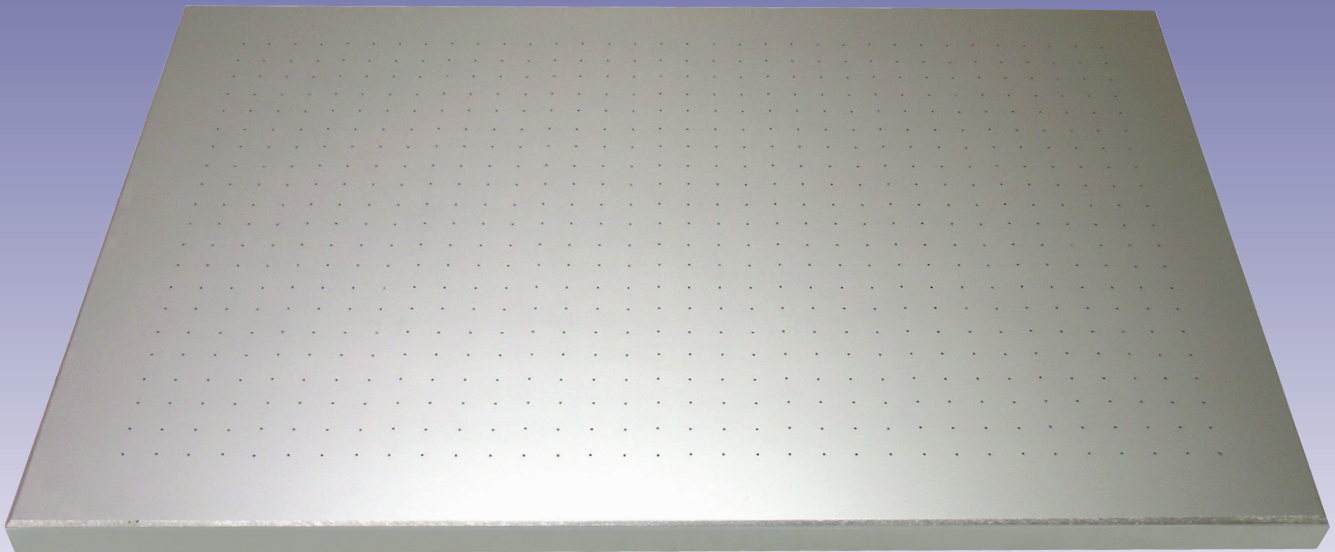

Rectangular table

Using Stay-Flat™ technology to guard against warping and covering them with the thickest top and bottom plates you'll find, these tables set the industry standard for flatness and durability.

The lightweight sandwich design yields a superior

strength-to-weight ratio, and the table's honeycomb core provides uniform airflow for maximum control of holddown.

Design and application optionS

Unusual configurations are routine for our engineers.

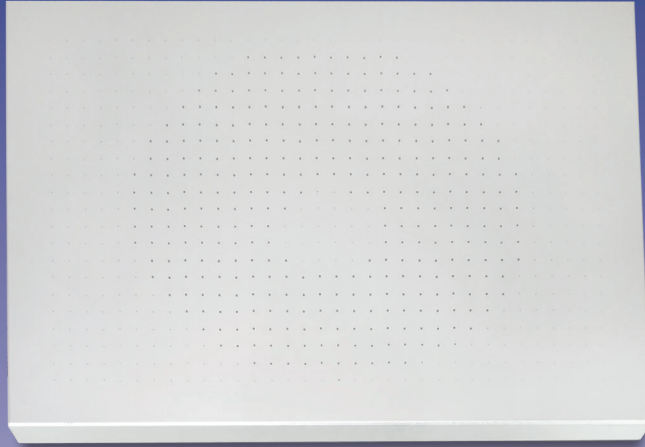

Rectangular table • Circular holddown pattern

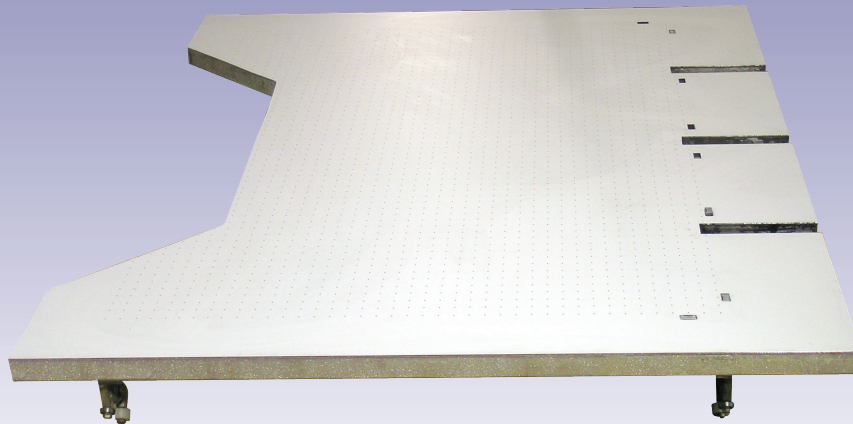

Polygon shape • Take-off cutouts • Disappearing guides

Unusual configurations are routine for our engineering department, a group of highly talented men and women who always find a way of implementing the most challenging requests.

While cutouts and threaded inserts are among the more frequently requested options, custom registration systems with disappearing guides are our specialty, and nobody integrates them as seamlessly as we do.

Design & Application OptionS

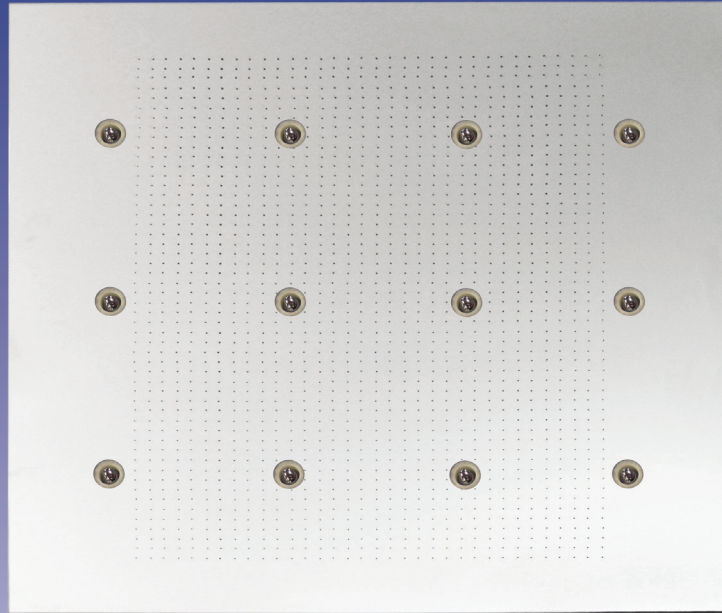

Recessed, pneumatically controlled rollers for easy removal of glass or other heavy panels.

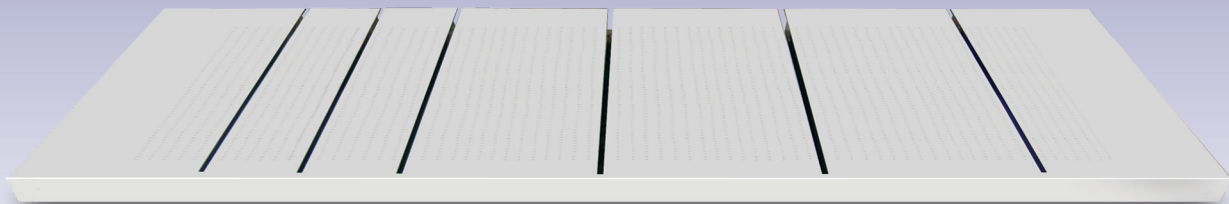

Cutouts designed for use with rigid panel transport systems.

Our vacuum tables excel at holding sensitive substrates in place during manufacturing as well as in R&D labs where rapid prototyping is required.

In working environments where a vacuum table's appearance is as important as its function, our finish really

shines. Edges are virtually seamless and every table looks as great as it performs.

Design & Application OptionS

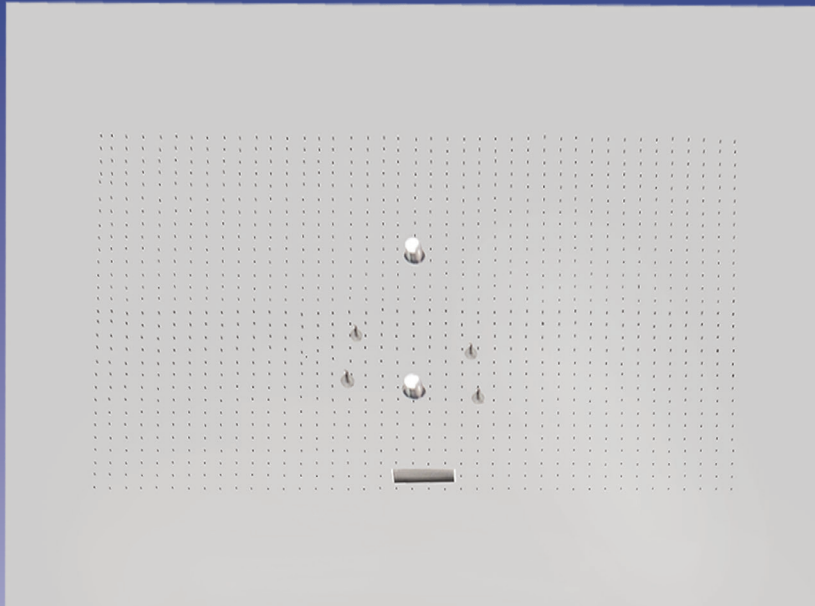

Lift pins • Disappearing guides • Camera well.

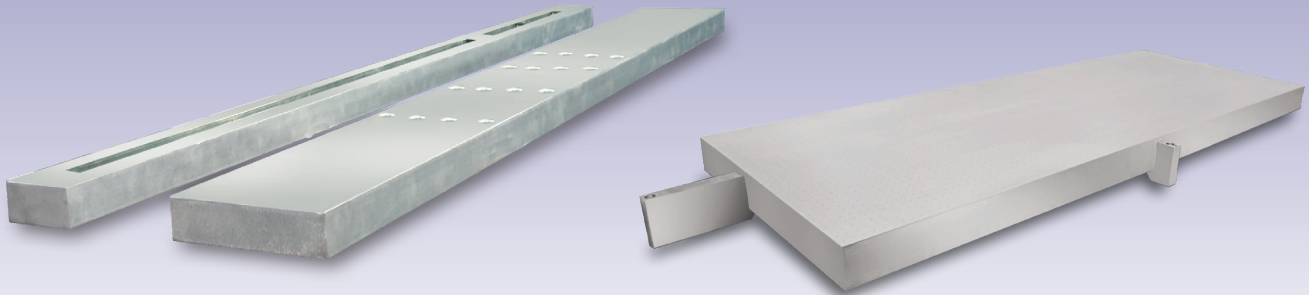

Slotted entrance and exit holddowns (left) for specialty manufacturing needs.

Side mounted registration collar (right) maximizes usable surface area.

Custom built to your specifications, our tables meet or exceed OEM requirements for smoothness, flatness and production endurance.

Design & Application OptionS

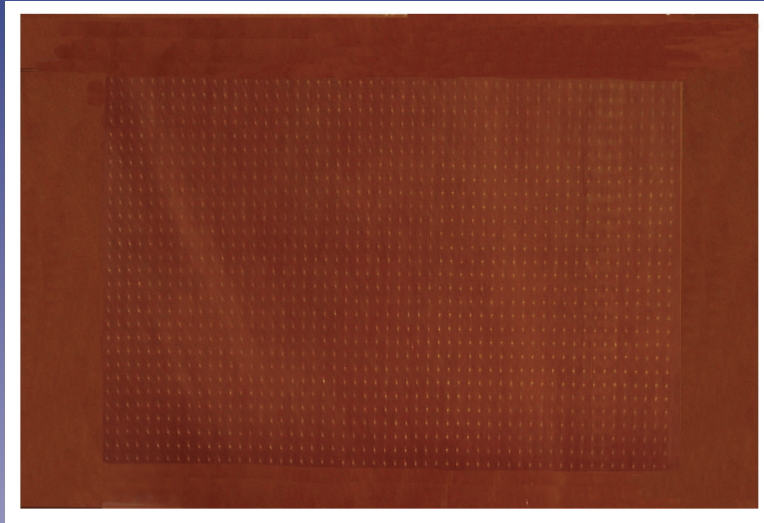

Custom phenolic surface for non-conductive applications.

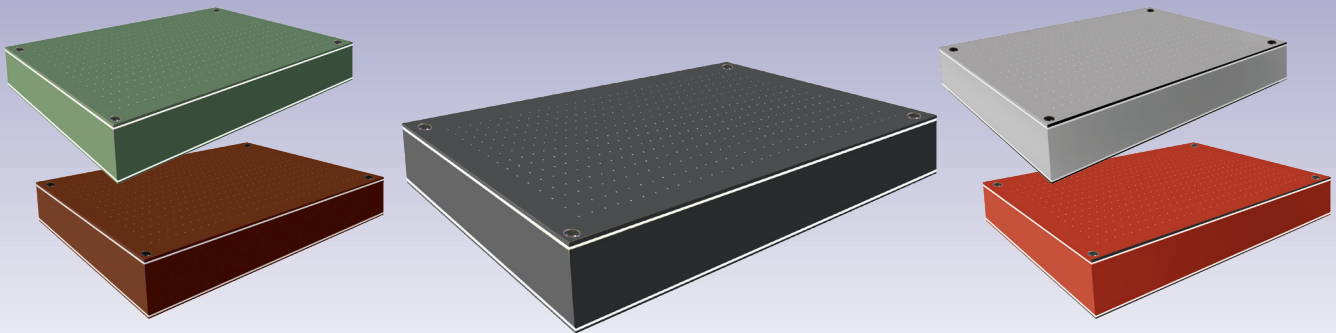

Anodized tables in a variety of colors.

We manufacture magnetic tops and phenolic surfaces for non-conductive and material sensitive applications and anodized tables in a variety of colors.

Vacuum tableS

Air flow Vacuum Holddown & Blowback SystemS

- Holds Flat and 3D Components in Place — Releases Material Easily
- Reduces Scratching — Excellent for Applications Requiring Flotation

Manual Vacuum Holddown SystemS

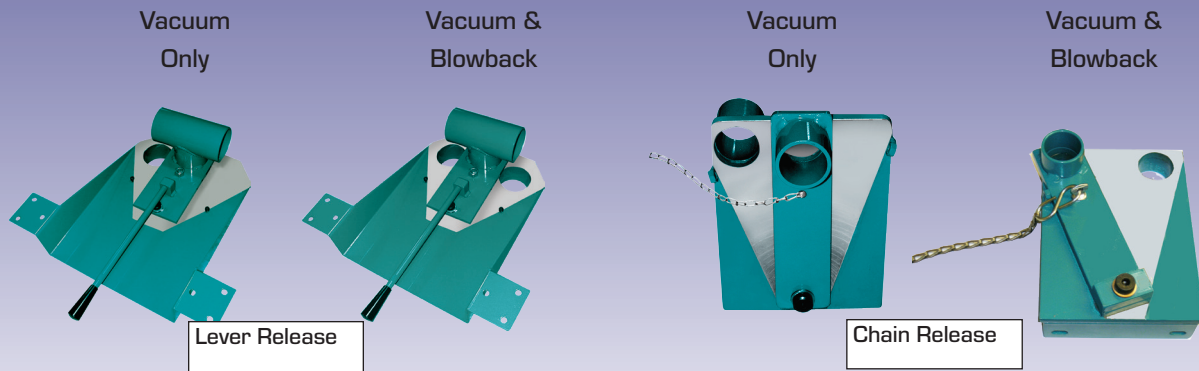

G.P.I. has developed innovative airflow vacuum holddown and flotation systems for flat or 3D substrates, components and parts. This unique system incorporates blowback or flotation of parts. As a result, friction and static are reduced. This also minimizes scratching the part as it is removed from the vacuum system.

Mount these versatile vacuum holddown systems easily wherever it is needed. It is easily accessible for maximum

control.

G.P.I. manufactures both manual and automated vacuum holddown & blowback systems. G.P.I. has all the parts required to assemble a complete vacuum system. Order using the part numbers listed below.

Manual Vacuum Holddown SystemS

Vacuum Only		Vacuum & Blowback		Vacuum Only		Vacuum & Blowback	
Part No	Hose Dia. (I.D.)	Part No	Hose Dia. (I.D.)	Part No	Hose Dia. (I.D.)	Part No	Hose Dia. (I.D.)
AFM-125M-GPI	1-1/4"	AFMB-125M-GPI	1-1/4"	AFC-125M-GPI	1-1/4"	AFCB-125M-GPI	1-1/4"
AFM-150M-GPI	1-1/2"	AFMB-150M-GPI	1-1/2"	AFC-150M-GPI	1-1/2"	AFCB-150M-GPI	1-1/2"
AFM-175M-GPI	1-3/4"	AFMB-175M-GPI	1-3/4"	AFC-175M-GPI	1-3/4"	AFCB-175M-GPI	1-3/4"
AFM-200M-GPI	2"	AFMB-200M-GPI	2"	AFC-200M-GPI	2"	AFCB-200M-GPI	2"
AFM-300M-GPI	3"	AFMB-300M-GPI	3"	AFC-300M-GPI	3"	AFCB-300M-GPI	3"



Airflow Vacuum Holddown & Blowback SystemS

- Holds Flat and 3D Components in Place — Releases Material Easily
- Reduces Scratching — Excellent for Applications Requiring Flotation

Automatic Vacuum Holddown SystemS

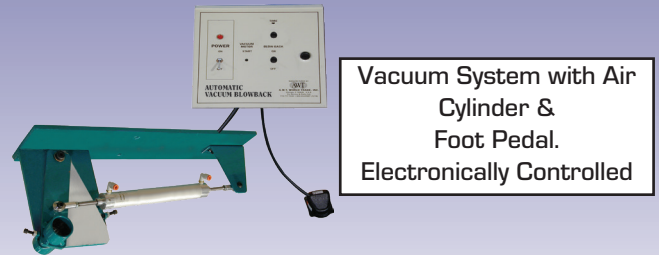
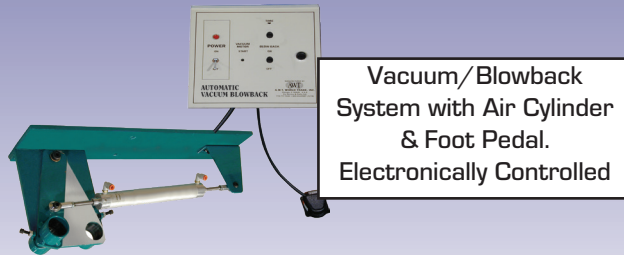

This G.P.I. system is complete with a foot pedal to make operation very easy to control. The on/off switch controls vacuum and blower. Blowback time can be preset

to control length of cycle. Electric and compressor are required to operate the cylinders and foot pedal in this system.

Automatic Vacuum Holddown SystemS

Part No	Vacuum& Blowback Hose Dia. (I.D.)	Electric
AFAB-125M-GPI	1-1/4"	115 V, 1 PH, 60 Hz
AFAB-150M-GPI	1-1/2"	115 V, 1 PH, 60 Hz
AFAB-175M-GPI	1-3/4"	115 V, 1 PH, 60 Hz
AFAB-200M-GPI	2"	115 V, 1 PH, 60 Hz
AFAB-300M-GPI	3"	115 V, 1 PH, 60 Hz

Part No	Vacuum Only Hose Dia. (I.D.)	Electric
AFA-125M-GPI	1-1/4"	115 V, 1 PH, 60 Hz
AFA-150M-GPI	1-1/2"	115 V, 1 PH, 60 Hz
AFA-175M-GPI	1-3/4"	115 V, 1 PH, 60 Hz
AFA-200M-GPI	2"	115 V, 1 PH, 60 Hz
AFA-300M-GPI	3"	115 V, 1 PH, 60 Hz

(Available in 220 V, 1 PH, 50 Hz; 3 PH also available)

Airflow AdjustmenT

Optional Fine-Tuning Controls Regulate Amount of Flow

Standard ConfigurationS

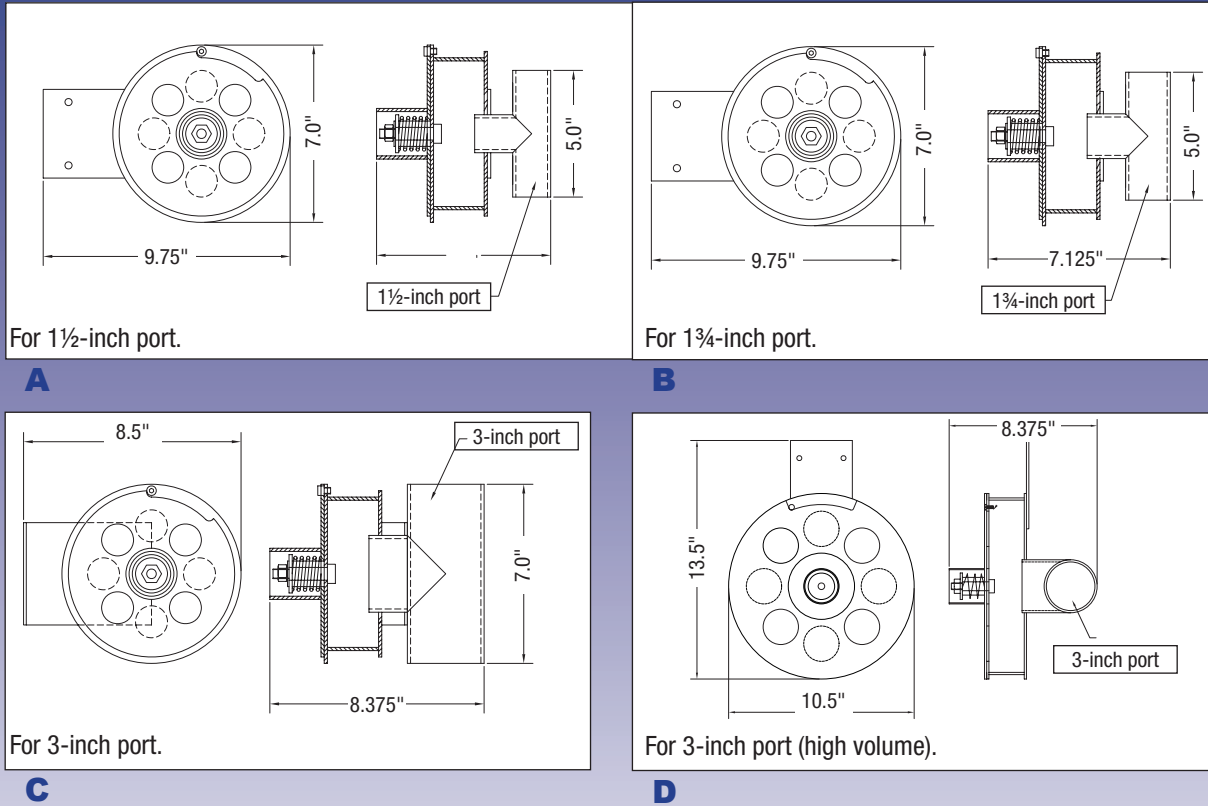

Vacuum/Air Flow Valves

	G.P.I. Part No	Fits Air Hoses (I.D.)	
A	GPIAFV-15	1-1/2"	38 mm
B	GPIAFV-134	1-3/4"	44.5 mm
C	GPIAFV-3	3"	76 mm
D	GPIAFV-3L	3" (high-volume)	76 mm

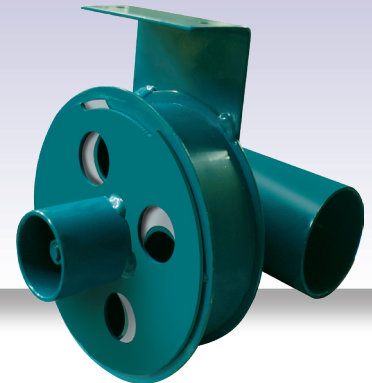

Varied ConfigurationS

G.P.I. manufactures air flow valves to fit ports for 1-1/2-, 1-3/4- and 3-inch air hoses (I.D.) to provide easy air adjustment through your system. (Custom sizes are also available.)

Precision air flow control is useful in overcoming problems such as in the case of thin substrates that “dimple” into vacuum holes. Also suitable for any application where control of airflow of anywhere from 0 to 100 percent is important.

Our engineers and technicians will help you choose the valves best suited to your needs or will provide custom designs on request. These units are built to last and will easily mount to your table or wherever you need them.

Vacuum tables

Vacuum Table FlangeS

Bottom Style

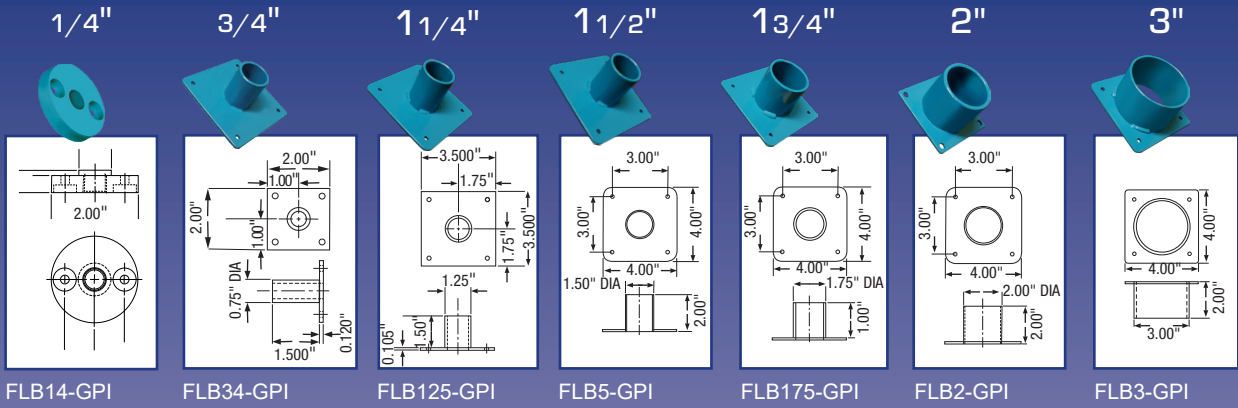

Edge Style

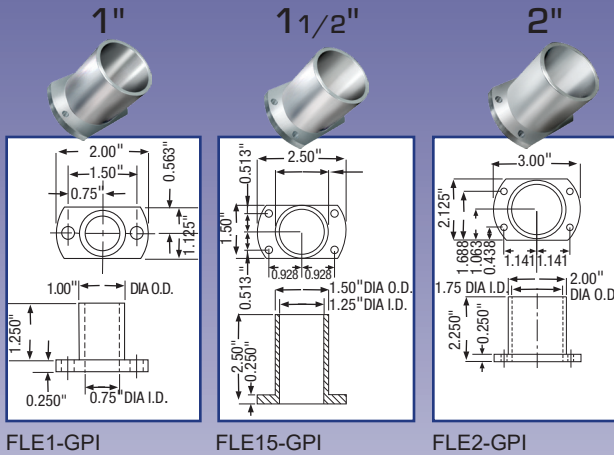

Angle Style

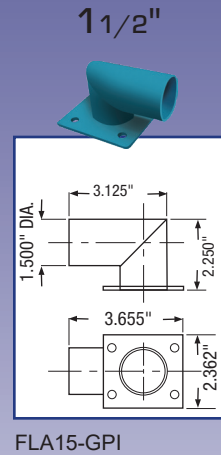

Hose Connectors

Tee Style

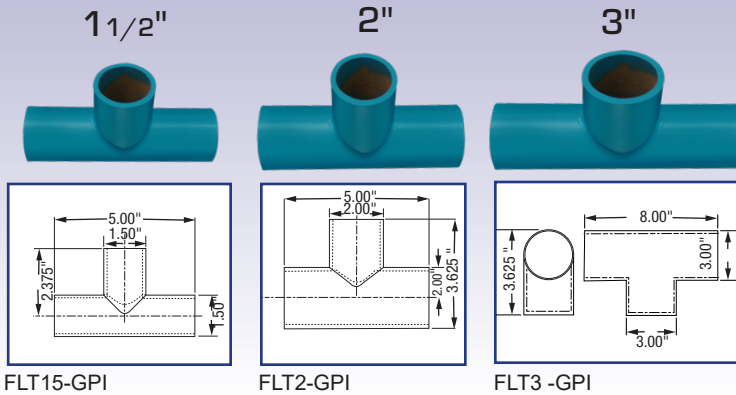

Manifolds



- MHC4-GPI Manifold 1.5" I.D / 1" O.D, 4 Port
- MHC6-GPI Manifold 3" I.D / 3" O.D, 6 Port
- MHC7-GPI Manifold 3" I.D / 3" O.D, 7 Port

Depending on the size of the vacuum table, one or more flanges will be strategically placed to provide maximum airflow/holddown power to each table zone when connected to a Max-Air™ vacuum motor.

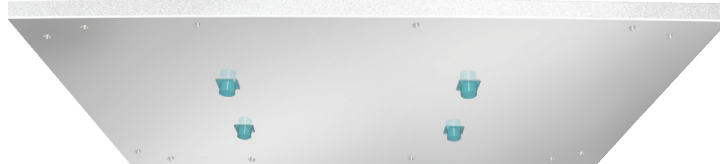

Heavy-Duty Vacuum HoseS

Designed to Handle the Demands and Pressures of Your System



G.P.I.'s heavy duty hoses and clamps complete your systems and are designed to handle demanding vacuum applications and pressures. Vacuum hoses come in



many standard sizes ranging from 1 1/4 to 3" but, as is the case with all G.P.I. products, custom sizes are also available.

Vacuum Hoses

GPIH125E	1 1/4"
GPIH150E	1 1/2"
GPIH175E	1 3/4"
GPIH40E	2"
GPIH3E	3"

Hose Clamps (Worm Drive)

GPIMD1116114	1 1/4"
GPISLD34234	1 1/2"
GPIH175E	1 3/4 - 3"

Vacuum Table Rebuilding

Like new performance and appearance

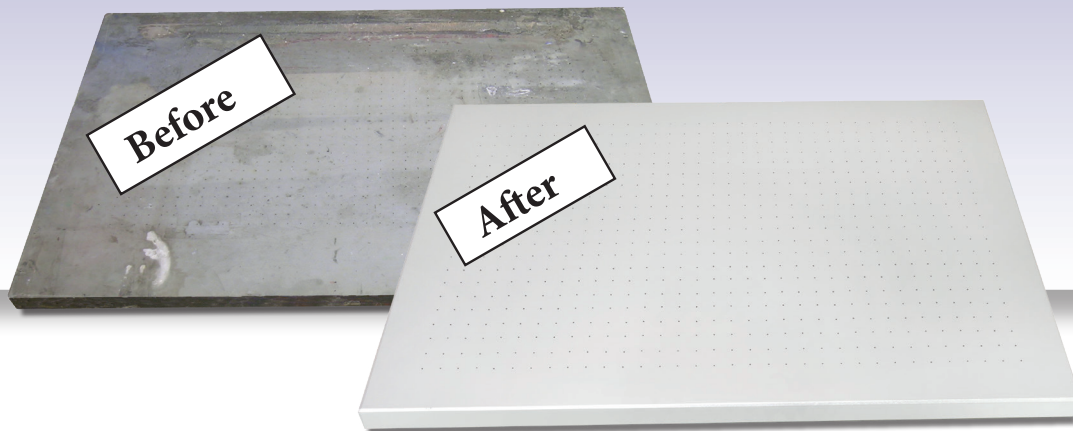

For customers who want to upgrade their existing vacuum table without the expense of buying a new one, G.P.I. offers a full range of rebuilding services designed to keep

costs down. Whether a table needs only resurfacing or is due for a complete overhaul, G.P.I. will restore the original look and performance.

Specialty Designs & ApplicationS

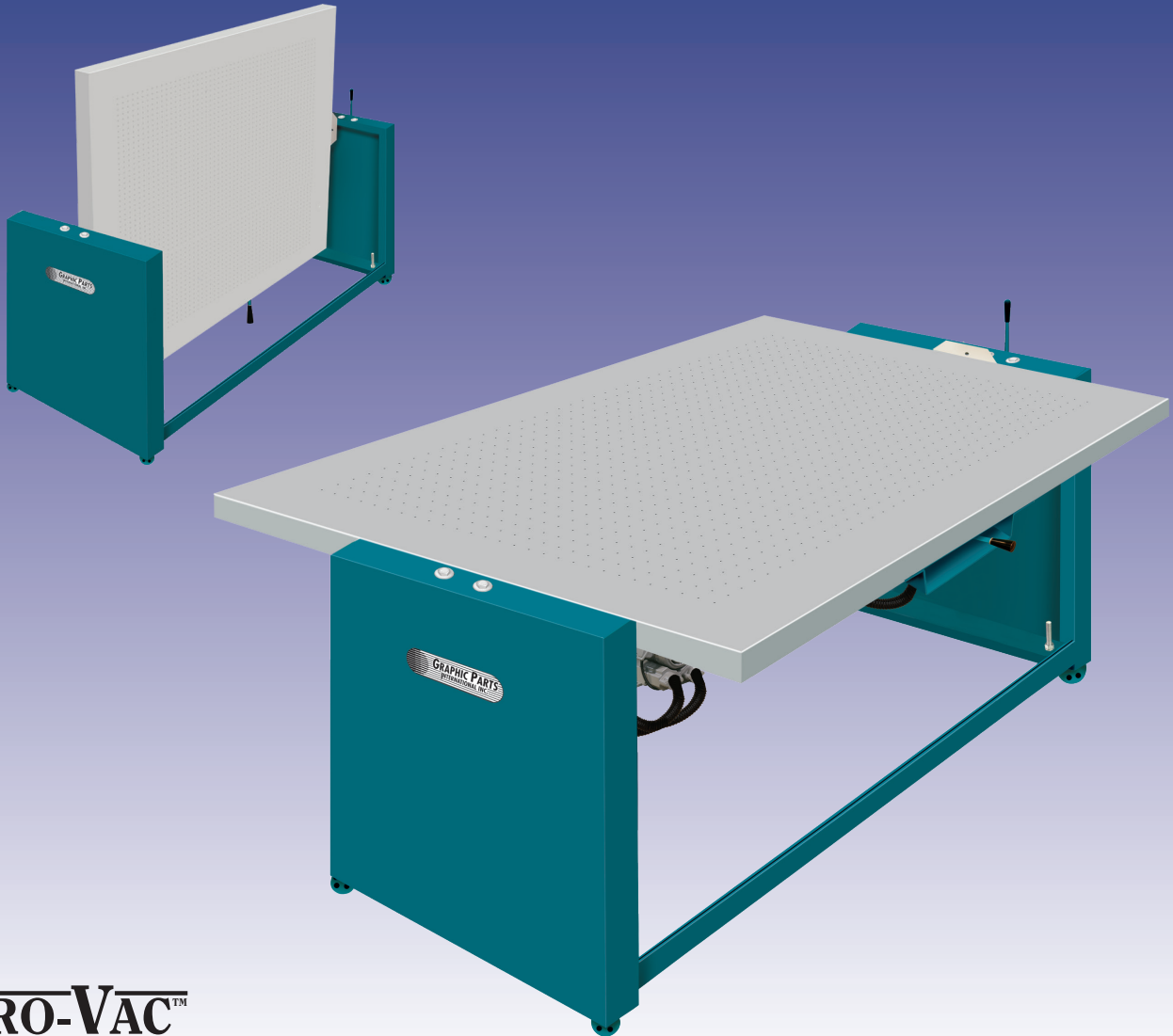

PRO-VAC™

The G.P.I. Pro-Vac™ is in a class by itself. In Autumn of 2010, a group of photo archivists asked if it was possible to manufacture a vacuum table which could be used both horizontally and vertically. Our engineers simply said, “no problem,” and the Pro-Vac was born. This unique table is connected to a heavy-duty, stainless-steel chassis which allows it to easily tilt 90° from a locked horizontal position to a locked vertical position and back.

Vacuum tableS

Please fill out this form completely. It is important to know the type of material, as well as it's thickness and size to fully develop the application.

You can simply make a copy of this page and either fax it to 773.725.0808 or email it to Michael Green at mgreen@awt-gpi.com If you have more than one application, please photocopy this page and fill the page out for each of your applications. Thank you.

1. MATERIAL TYPE: _____

2. MATERIAL SIZE: (Minimum) - _____ Maximum – _____

3. MATERIAL THICKNESS: (Minimum) - _____ Maximum – _____

4. MATERIAL WEIGHT: _____ (lbs.) _____ (cm)

(Minimum) - _____ Maximum – _____



MAX-AIR™

Series of Vacuum MotorS

Max-Air motors are designed to meet the most critical application requirements.

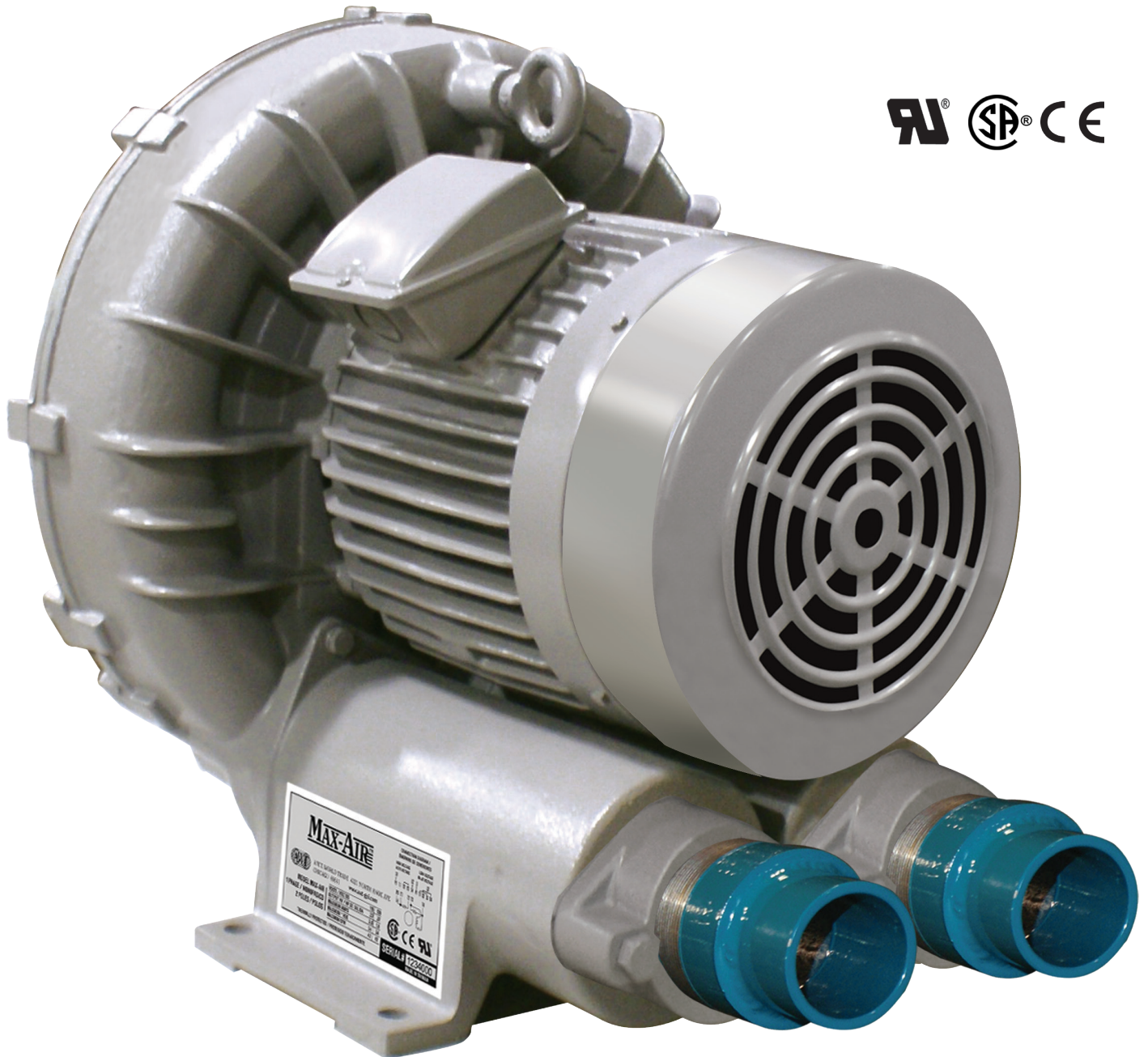

Overview

Features

1. Suction and discharge silencers
2. Die cast impeller
3. Dynamically balanced impeller
4. Double shielded shaft bearing
5. Dust-proof shaft seal
6. Motor shaft-mounted impeller
7. 50/60 Hz motors, wide voltage range
8. Improved cooling fan design
9. Built-in thermal protector
10. Compact design
11. Removable threaded flanges

Advantages

1. Reduces noise levels to below OSHA standards. Makes it more comfortable for operators working near the motors.
2. Promotes smoother air flow and higher volumetric efficiency.
3. Smoother operation. Allows vibration-free installation in OEM equipment.
4. Better grease retention, increased reliability.
5. Protects bearings from contaminants for longer life.
6. Eliminates the need for couplings, belts or gears. Nothing to break or wear out.
7. Minimizes OEM inventory requirements.
8. Cools the motor and blower. Quieter running and more efficient.
9. Protects the motor from overheating for greater reliability.
10. Space saving design makes it easier for OEM's to incorporate the motor into their equipment.
11. Easy replacement in OEM equipment.

Housing

Shaft Seal

Double Shielded Bearing

Direct Motor-Impeller Drive

Dynamically Balanced Impeller

50/60 Hz Squirrel-Cage TEFC Motor

Built-in Thermal Protector

Terminal Box

Removable Threaded Flanges

Built-in Silencer

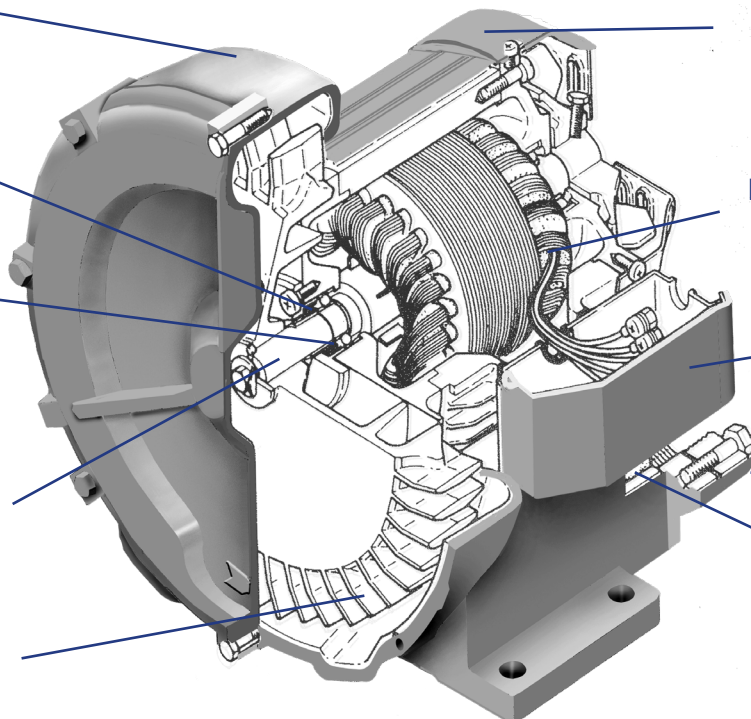

GPI-VM32-150

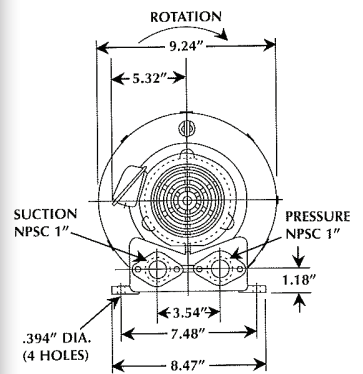
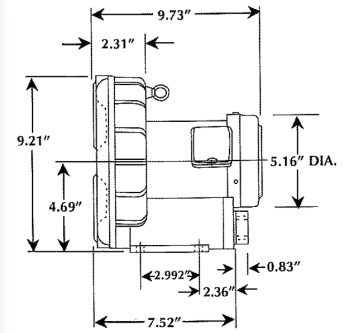

The Max-Air model GPI-VM32-150 is a single-stage ring compressor with a maximum pressure of 37 in. H₂O, a maximum vacuum of 34 in. H₂O, and a maximum capacity of 42 SCFM. It comes complete with a direct-drive,

1/3 horsepower, TEFC motor capable of operating on a wide range of voltages, and on 50 or 60 Hz. A pilot-duty thermal protector is standard equipment on all 3-phase models, and built-in automatic reset thermal

protectors on 1-phase units. All version have NEMA class B insulation, are UL recognized, CSA certified and CE.

Model No. *	Inlet-Outlet NPSC Ports	Hz	Voltage	Amps (Max. Rated)	Amps (Locked Rotor)	HP	Max. Pressure in. H ₂ O	Max. Vacuum in. H ₂ O	Max. Airflow SCFM	Min. Airflow SCFM	Min. Temp Rise (ΔT) °F [°C]	Weight lbs.(kg)
			Low Voltage / High Voltage									
GPI-VM32-150	1.5"	1 Phase	60	115/230	3.6/1.8	11/5.5	34	33	42	3.5	72 (40)	22 (10)
			50	110/220	3.0/1.5	10/5	26	25	35	3.5	65 (35)	
GPI-VM32A-150	1.5"	3 Phase	60	200-240/400-480	1.2-1.2/0.6-0.6	5.2-6.0/2.6-3.0	37	34	42	3.5	(40)	
			50	190-230/380/460	1.0-1.1/0.5-0.55	5.8-6.6/2.9-3.3	26	25	35	3.5	65 (35)	

PERFORMANCE DATA GPI-VM32-150

PRESSURE

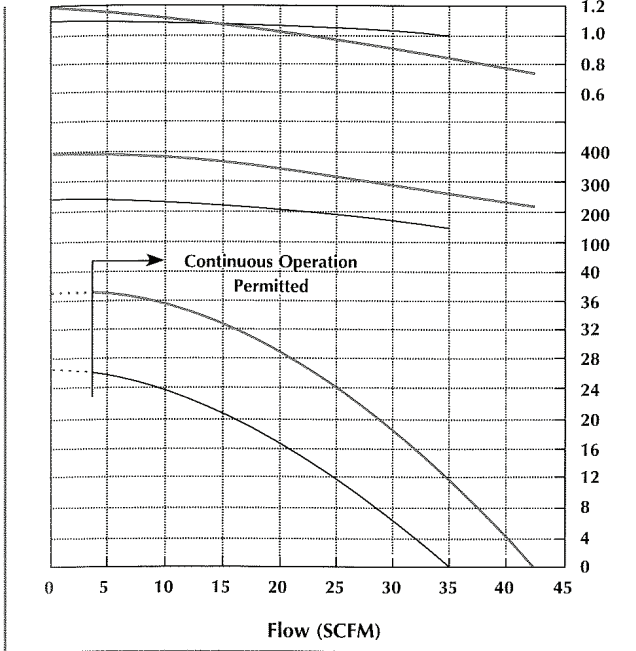

VACUUM

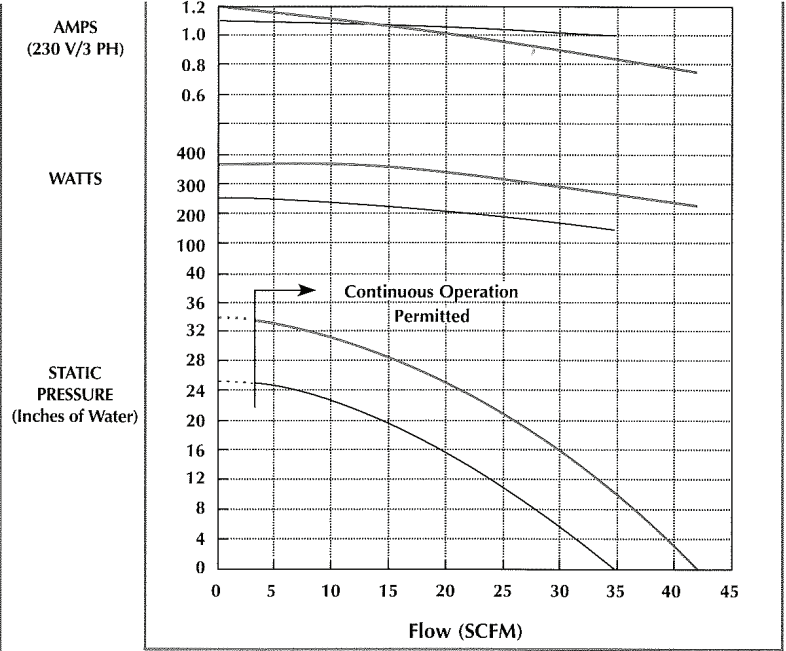

— 60 Hz
 - - - 50 Hz

TEMPERATURE RISE

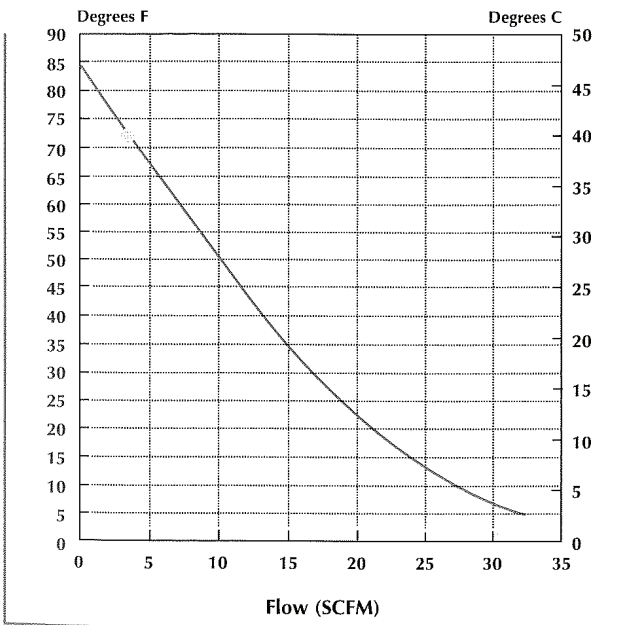

Max. Air Temperature is Value Marked • plus 40 Degrees C Ambient Temperature

SOUND LEVEL

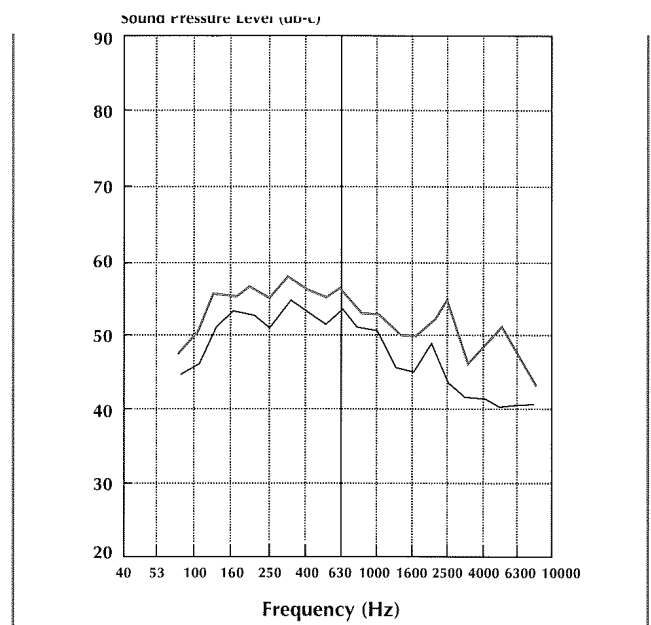

*Measured at distance of 1.0 meters

GPI-VM48-150

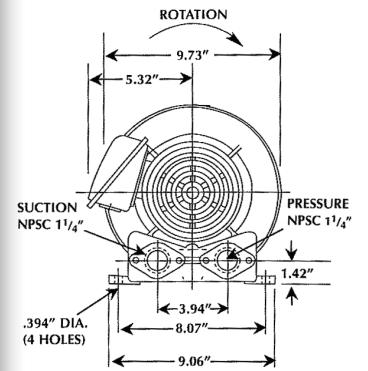
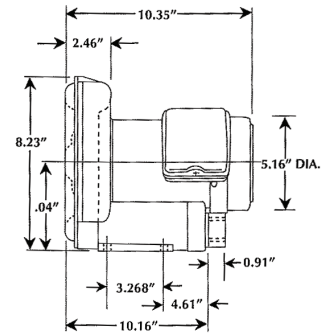

The Max-Air model GPI-VM48-150 is a single-stage ring compressor with a maximum pressure of 50 in. H₂O, a maximum vacuum of 45 in. H₂O, and a maximum capacity of 56 SCFM. It comes complete with a direct-drive,

1/2 horsepower TEFC motor capable of operating on a wide range of voltages, and on 50 or 60 Hz. A pilot-duty thermal protector is standard equipment on all 3-phase models, and built-in automatic reset thermal protectors on

1-phase units. All version have NEMA class B insulation, are UL recognized, CSA certified and CE.

Model No. *	Inlet-Outlet NPSC Ports	Hz	Voltage	Amps (Max. Rated)	Amps (Locked Rotor)	HP	Max. Pressure in. H ₂ O	Max. Vacuum in. H ₂ O	Max. Airflow SCFM	Min. Airflow SCFM	Min. Temp Rise (ΔT) °F (°C)	Weight lbs.(kg)
			Low Voltage / High Voltage									
GPI-VM48-150	1.5"	1 Phase	60	115/230	5.0/2.5	17/8.5	49	45	56	17	54 (30)	27 (12.3)
			50	110/220	3.8/1.9	15/7.5	38	34	49	10	47 (27)	
GPI-VM48A-150	1.5"	3 Phase	60	200-240/400-480	1.5-1.7/0.75-0.85	7.2-8.0/3.6-4.0	50	45	55	17	54(30)	25.5 (11.5)
			50	190-230/380/460	1.4-1.7/0.7-0.85	8.0-8.8/4.0-4.0	40	36	47	10	47 (27)	

PERFORMANCE DATA GPI-VM48-150

PRESSURE

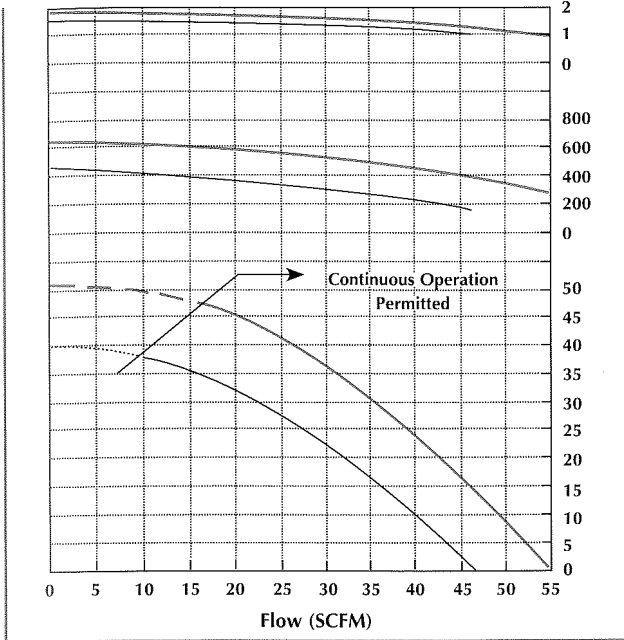

VACUUM

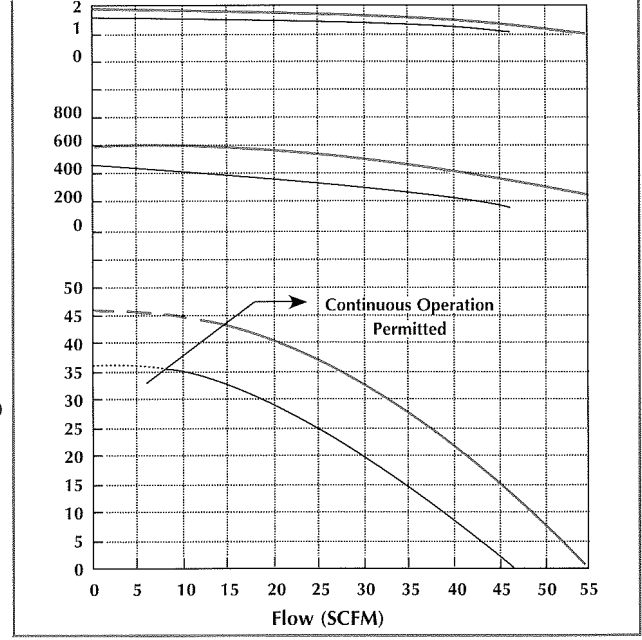

TEMPERATURE RISE

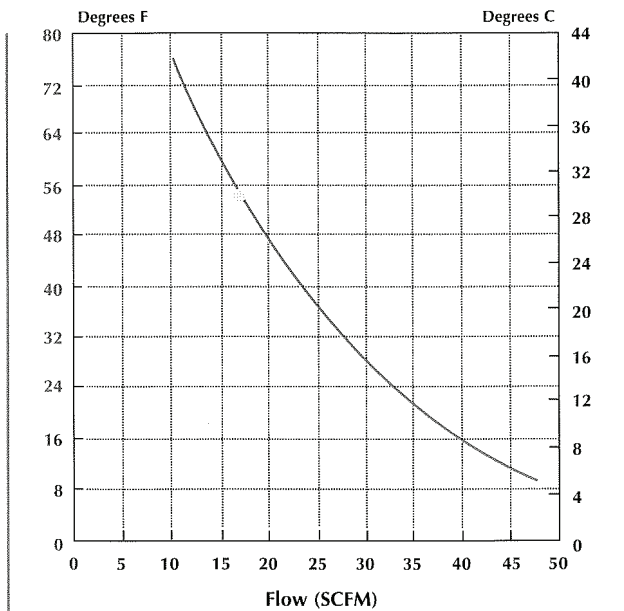

Max. Air Temperature is Value Marked • plus 40 Degrees C Ambient Temperature

SOUND LEVEL

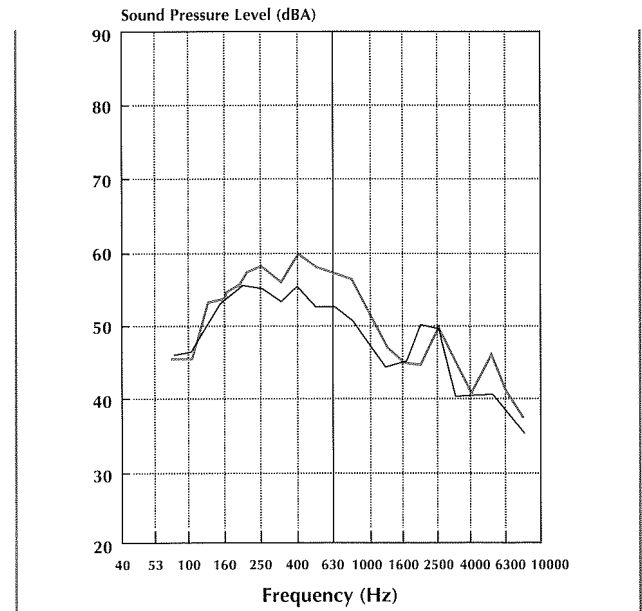

*Measured at distance of 1.0 meter

— 60 Hz
— 50 Hz

GPI-VM64-150

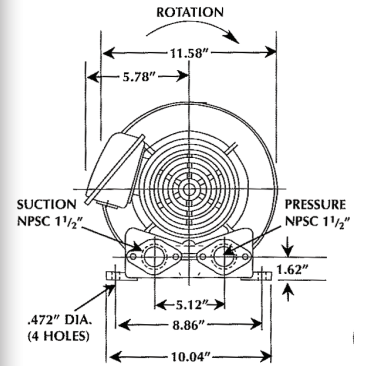
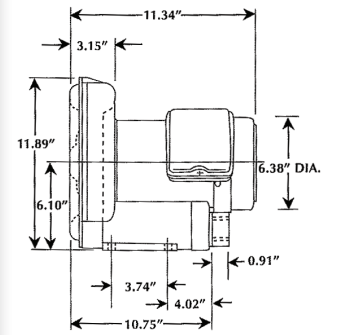

The Max-Air model GPI-VM64-150 is a single-stage ring compressor with a maximum pressure of 54.5 in. H₂O, a maximum vacuum of 50 in. H₂O, and a maximum capacity of 98 SCFM. It

comes complete with a direct-drive, 1 horsepower TEFC motor capable of operating on a wide range of voltages, and on 50 or 60 Hz. A pilot-duty thermal protector is standard equipment on all

3-phase and 1-phase models. All versions have NEMA class B insulation, are UL recognized, CSA certified and CE.

Model No. *	Inlet-Outlet NPS Ports	Hz	Voltage	Amps (Max. Rated)	Amps (Locked Rotor)	HP	Max. Pressure	Max. Vacuum	Max. Airflow	Min. Airflow	Min. Temp Rise (ΔT)	Weight	
			Low Voltage / High Voltage				in. H ₂ O	in. H ₂ O	SCFM	SCFM	°F [°C]	lbs.(kg)	
GPI-VM64-150	1.5"	1 Phase	60	115/230	5.0/2.5	17/8.5	1	49	45	56	17	54 (30)	51 (23)
GPI-VM64-175	1.75"		50	110/220	3.8/1.9	15/7.5	1	38	34	49	10	47 (27)	
GPI-VM64-300	3.0"	3 Phase	60	200-240/400-480	1.5-1.7/0.75-0.85	7.2-8/3.6-4	1	50	45	55	17	72 (40)	
			50	190-230/380/460	1.4-1.7/0.7-0.85	8-8.8/4-4.4	1	40	36	47	10	65 (35)	

*Specifications are the same for all three models except for NPS Port size

PERFORMANCE DATA GPI-VM64-150

PRESSURE

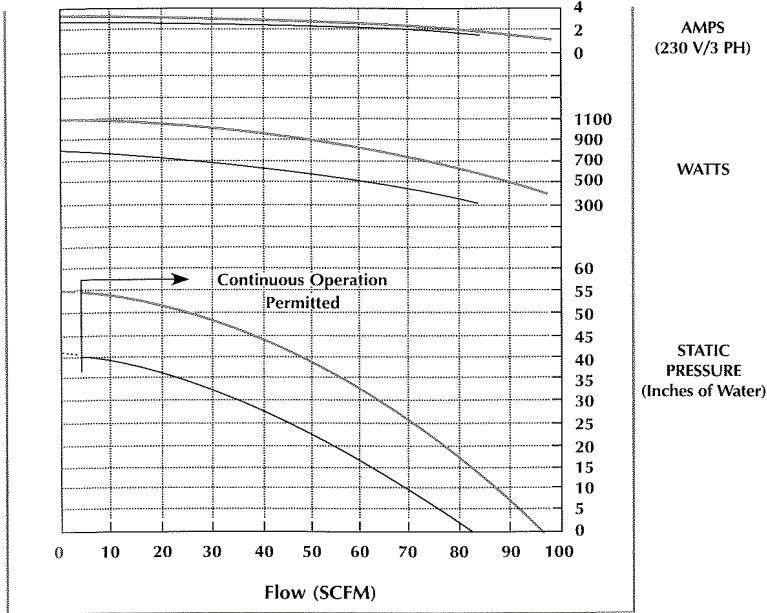

VACUUM

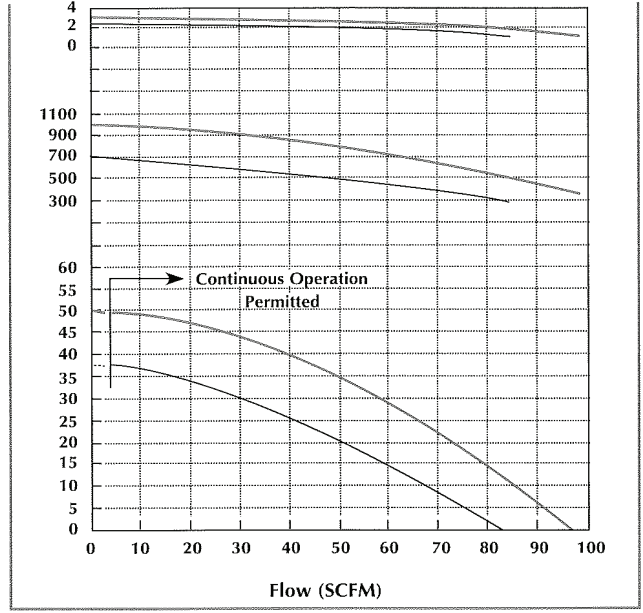

— 60 Hz
— 50 Hz

TEMPERATURE RISE

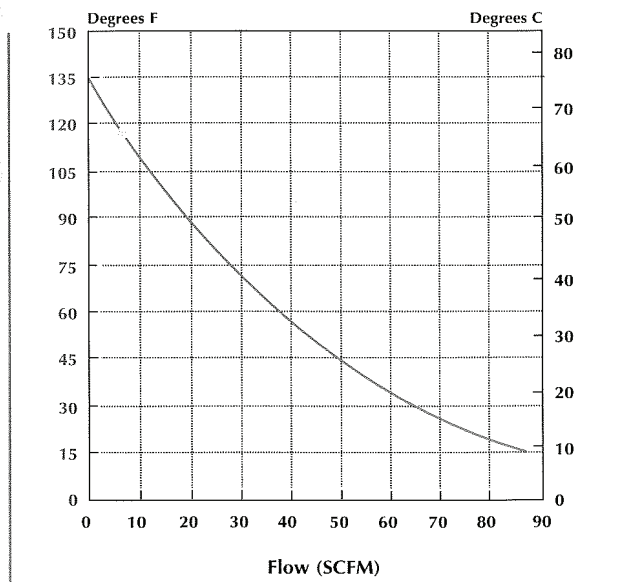

Max. Air Temperature is Value Marked • plus 40 Degrees C Ambient Temperature

SOUND LEVEL

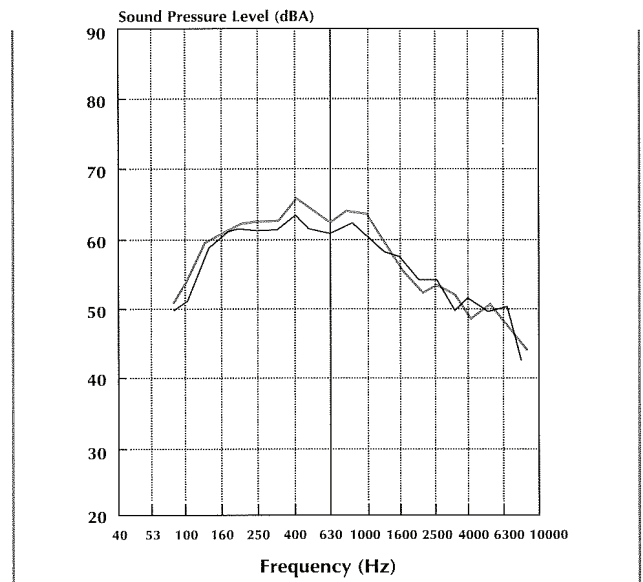

*Measured at distance of 1.0 meter

GPI-VM80-300

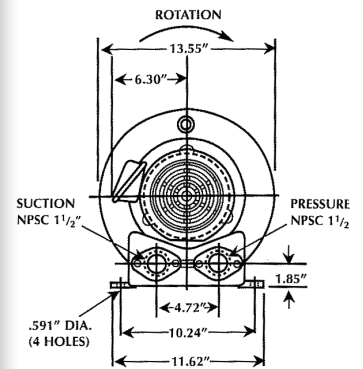
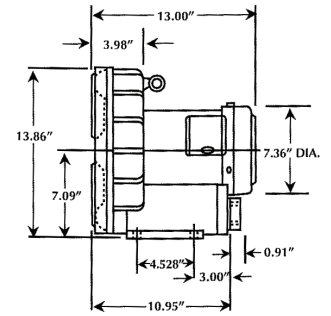

The Max-Air model GPI-VM80-300 is a single-stage ring compressor with a maximum pressure of 54.5 in. H₂O, a maximum vacuum of 50 in. H₂O, and a maximum capacity of 98 SCFM. It

comes complete with a direct-drive, 1 horsepower TEFC motor capable of operating on a wide range of voltages, and on 50 or 60 Hz. A pilot-duty thermal protector is standard equipment on all

3-phase and 1-phase models. All versions have NEMA class B insulation, are UL recognized, CSA certified and CE.

Model No. *	Inlet-Outlet NPSC Ports	Hz	Voltage	Amps (Max. Rated)	Amps (Locked Rotor)	HP	Max. Pressure	Max. Vacuum	Max. Airflow	Min. Airflow	Min. Temp Rise (ΔT)	Weight
							in. H ₂ O	in. H ₂ O	SCFM	SCFM	°F [°C]	
Low Voltage / High Voltage												
GPI-VM80-300	3.0"	1 Phase	60	200/230	12-11	70-80	80	70	154	60	72 (40)	97.5 (44)
			50	200/220	8.5-8	70-75	60	53	130	45	65 (35)	
GPI-VM80A-300	3.0"	3 Phase	60	200-240/400-480	6.9-6.2/3.4-3.1	44-52/22-26	80	70	154	45	101 (55)	
			50	190-230/380/460	5.2-5.4/2.6-2.7	48-56/24-28	60	53	130	25	72 (40)	

PERFORMANCE DATA GPI-VM80-300

PRESSURE

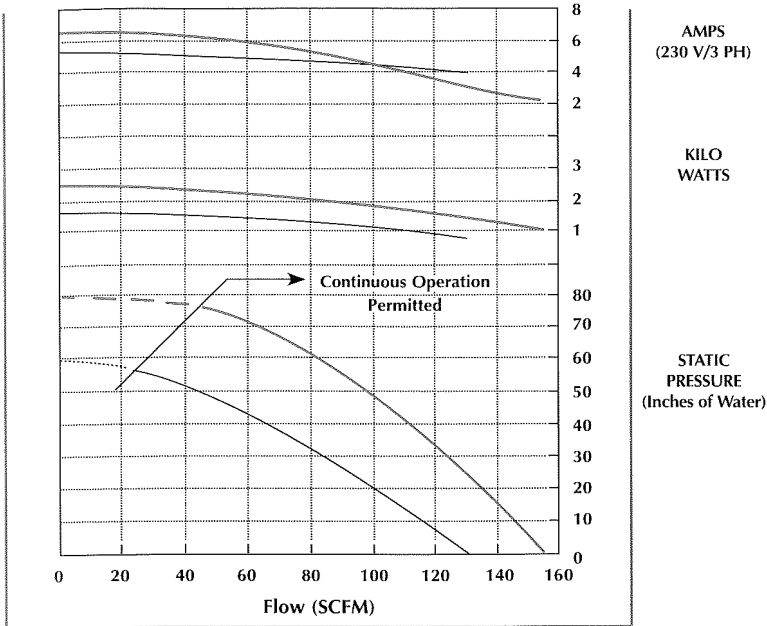

VACUUM

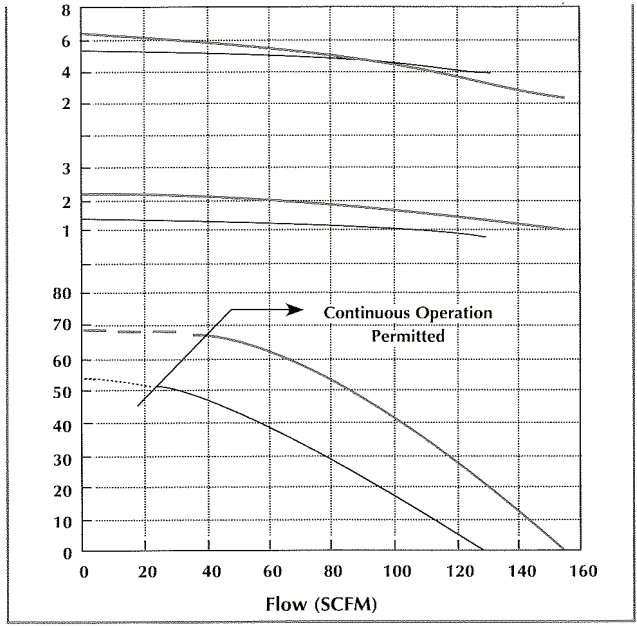

— 60 Hz
— 50 Hz

TEMPERATURE RISE

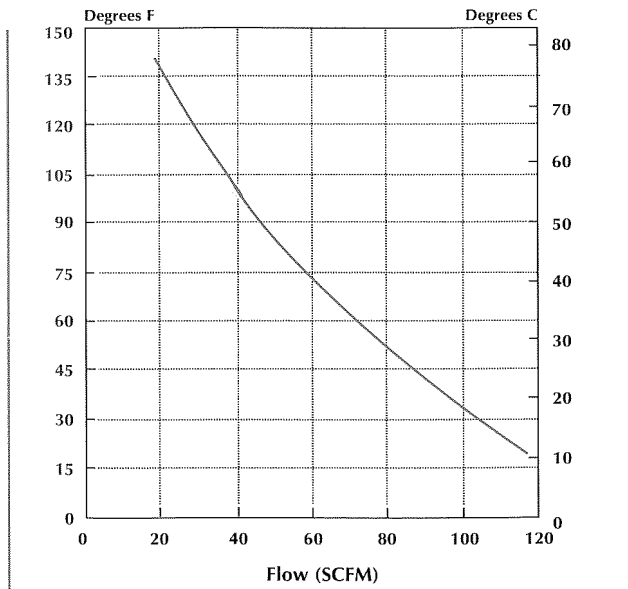

Max. Air Temperature is Value Marked • plus 40 Degrees C Ambient Temperature

SOUND LEVEL

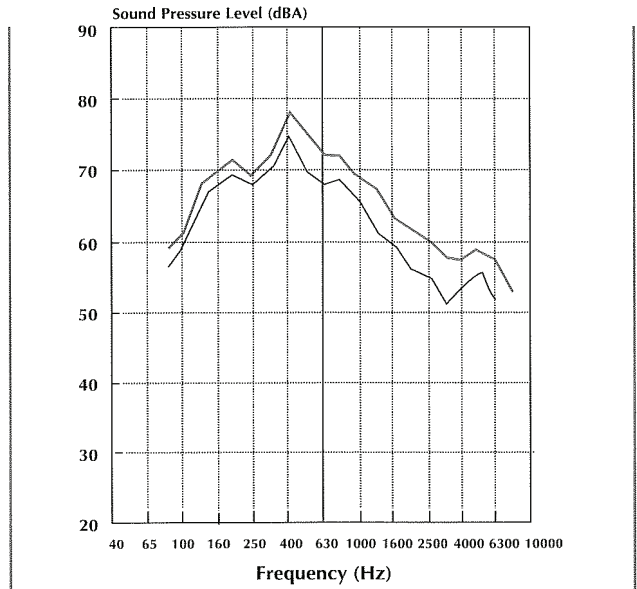

*Measured at distance of 1.0 meter

GPI-VM96-300

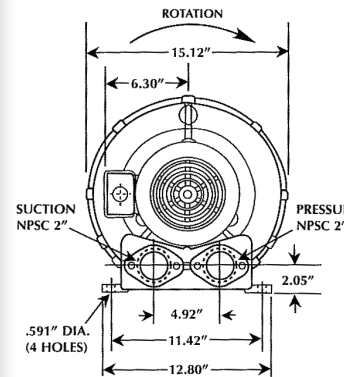
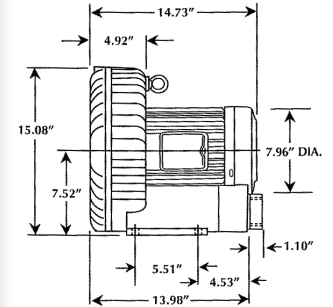

The Max-Air model GPI-VM96-300 is a single-stage ring compressor with a maximum pressure of 118 in. H₂O, a maximum vacuum of 98 in. H₂O, and a maximum capacity of 206 SCFM. It comes complete with a direct-drive,

4.5 horsepower TEFC motor capable of operating on a wide range of voltages, and on 50 or 60 Hz. A pilot-duty thermal protector is standard equipment on all 3-phase models. All versions have NEMA class B insulation, are UL recog-

nized, CSA certified and CE. 575 Volt units are CSA certified only.

Model No. *	Inlet-Outlet NPSC Ports	Hz	Voltage	Amps (Max. Rated)	Amps (Locked Rotor)	HP	Max. Pressure	Max. Vacuum	Max. Airflow	Min. Airflow	Min. Temp Rise (ΔT)	Weight	
							in. H ₂ O	in. H ₂ O	SCFM	SCFM	°F (°C)		
			Low Voltage / High Voltage										
GPI-VM96A-300	3.0"	3 Phase	60	200-240/400-480	12-11/6.0-5.5	78-90/39-45	4.5	118	45	55	17	72 (40)	114 (52)
			50	190-230/380/460	9.2-10/4.6-5.2	88-102/44-51		86	36	47	10	65 (35)	
			60	575	4.4	36		118	98	206	56	126 (70)	

PERFORMANCE DATA GPI-VM96-300

PRESSURE

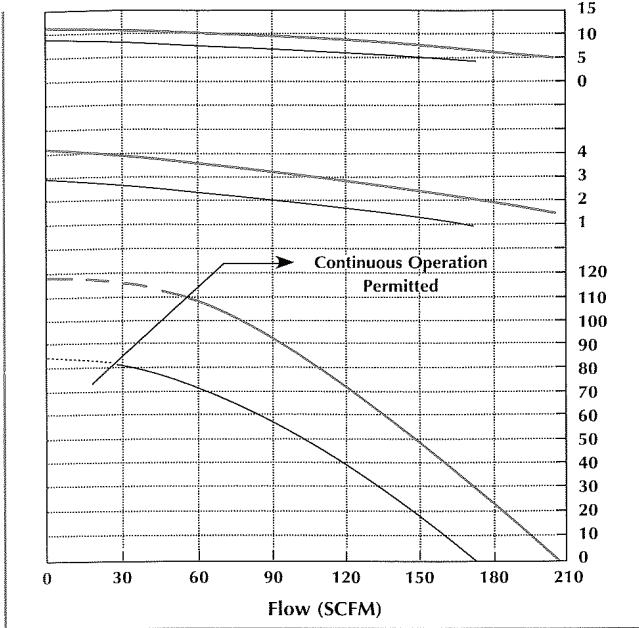

VACUUM

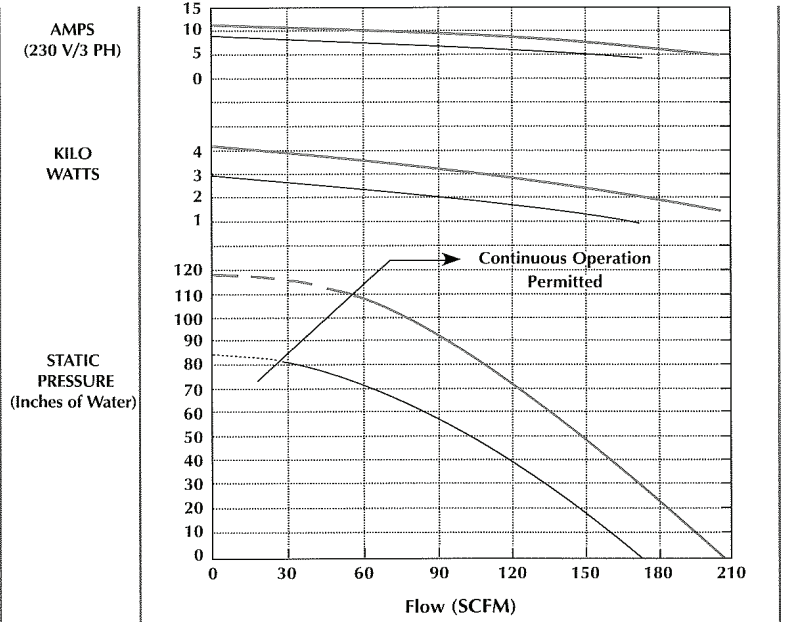

TEMPERATURE RISE

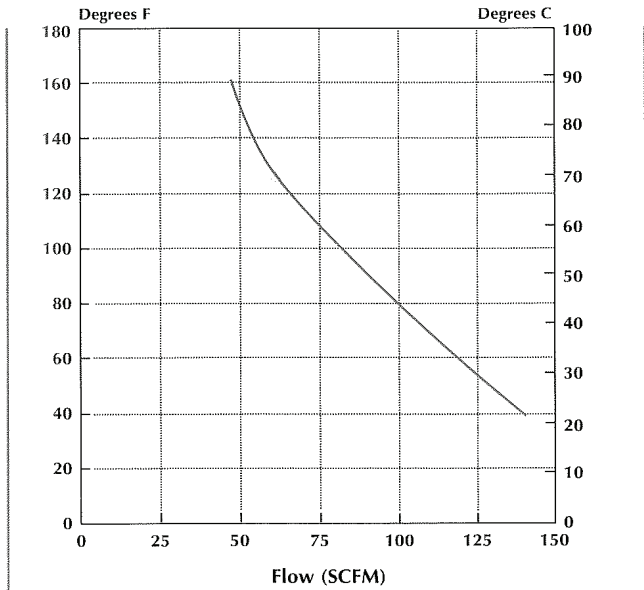

Max. Air Temperature is Value Marked • plus 40 Degrees C Ambient Temperature

SOUND LEVEL

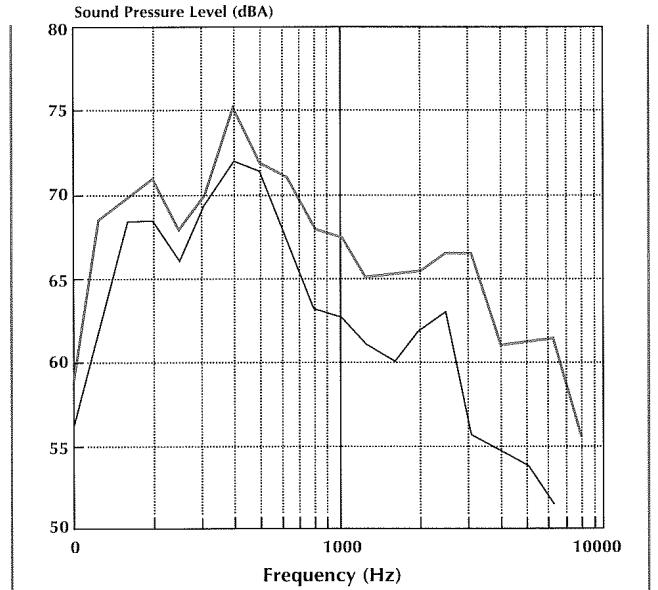

*Measured at distance of 1.0 meter

GPI-VM112-300

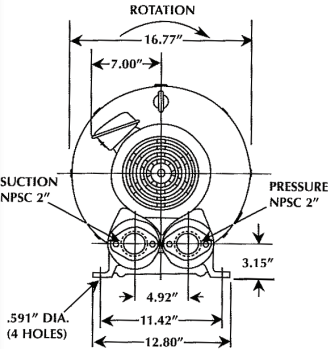
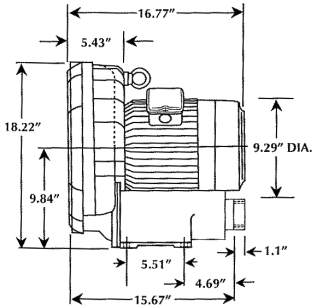

The Max-Air model GPI-VM112-300 is a single-stage ring compressor with a maximum pressure of 114 in. H₂O, a maximum vacuum of 96 in. H₂O, and a maximum capacity of 267 SCFM. It comes complete with a

direct-drive, 7 horsepower TEFC motor capable of operating on a wide range of voltages, and on 50 or 60 Hz. A pilot-duty thermal protector is standard equipment on all 3-phase models. All versions have NEMA class B insulation,

are UL recognized, CSA certified and CE. 575 Volt units are CSA certified only.

Model No. *	Inlet-Outlet NPSC Ports	Hz	Voltage	Amps (Max. Rated)	Amps (Locked Rotor)	HP	Max. Pressure	Max. Vacuum	Max. Airflow	Min. Airflow	Min. Temp Rise (ΔT)	Weight
							in. H ₂ O	in. H ₂ O	SCFM	SCFM	°F (°C)	
Low Voltage / High Voltage												
GPI-VM112A-300	3.0"	3 Phase	60	200-240/400-480	15.6-16/7.8-8.0	110-115/50-58	114	96	267	88	137 (75)	180 (82)
			50	190-230/380/460	13-14/6.5-7.0	104-128/52-64	81	71	220	63	108 (60)	
			60	575	6.7	35	114	96	267	88	137 (75)	

PERFORMANCE DATA GPI-VM1 12-300

PRESSURE

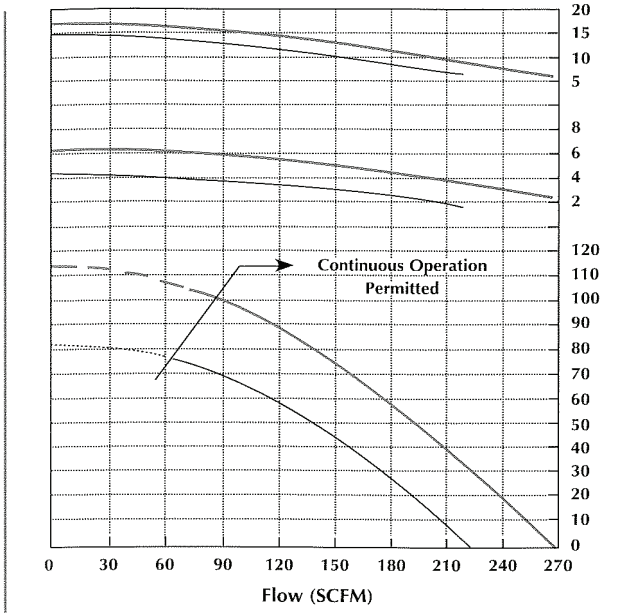

VACUUM

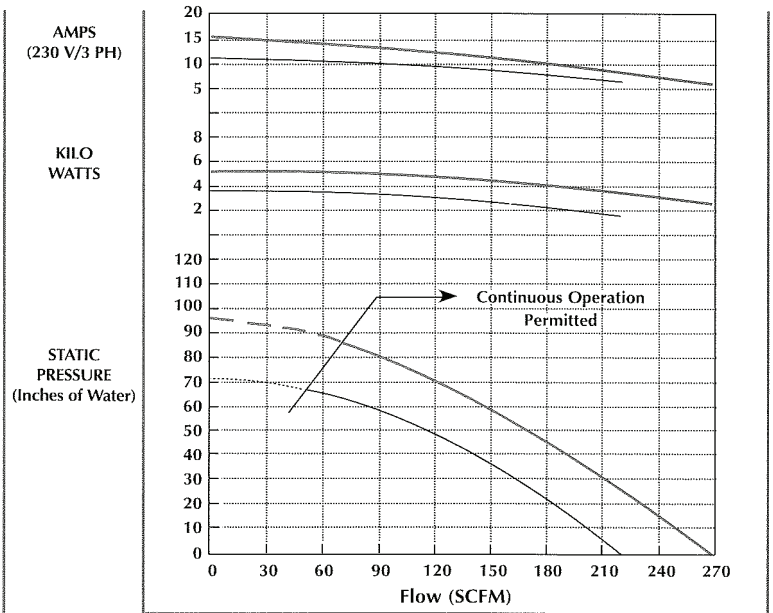

— 60 Hz
— 50 Hz

TEMPERATURE RISE

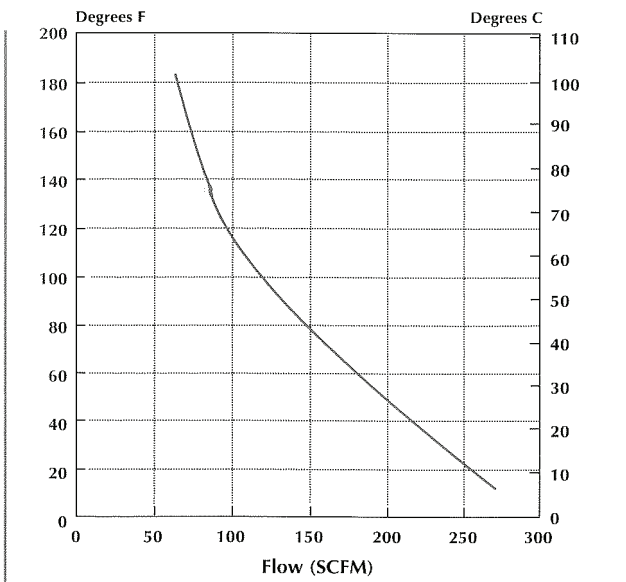

Max. Air Temperature is Value Marked • plus 40 Degrees C Ambient Temperature

SOUND LEVEL

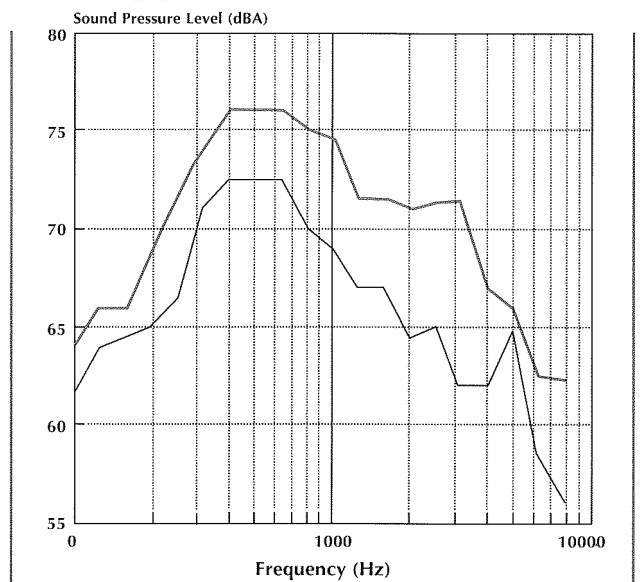

*Measured at distance of 1.0 meter

GPI-VM128-300

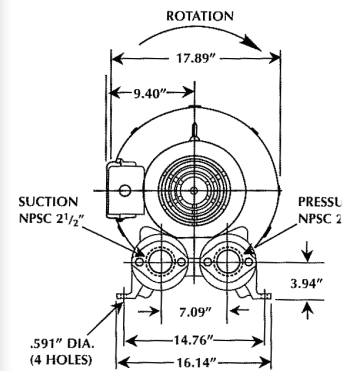
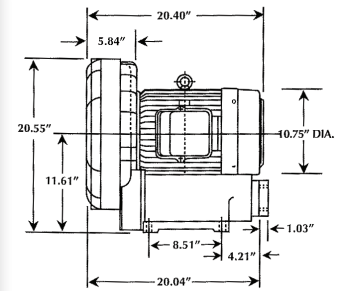

The Max-Air model GPI-VM128-300 is a single-stage ring compressor with a maximum pressure of 135 in. H₂O, a maximum vacuum of 110 in. H₂O, and a maximum capacity of 388 SCFM. It comes complete with

a direct-drive, 10 horsepower TEFC motor capable of operating on a wide range of voltages, and on 50 or 60 Hz. A pilot-duty thermal protector is standard equipment on all 3-phase models. All versions have NEMA class B insulation,

are UL recognized, CSA certified and CE. 575 Volt units are CSA certified only.

Model No.	Inlet-Outlet NPSC Ports	Hz	Voltage	Amps (Max. Rated)	Amps (Locked Rotor)	HP	Max. Pressure	Max. Vacuum	Max. Airflow	Min. Airflow	Min. Temp Rise (ΔT)	Weight	
			Low Voltage / High Voltage				in. H ₂ O	in. H ₂ O	SCFM	SCFM	°F (°C)	lbs.(kg)	
GPI-VM128-300	30"	3 Phase	60	200-240/400-480	26-23/13-11.5	144-160/72-80	10	135	110	388	135	137 (75)	287 (130)
			50	190-230/380/460	18-19/9.0-9.5	164-190/82-95		100	83	320	88	137 (75)	
			60	575	9.2	66		135	110	388	135	137 (75)	

PERFORMANCE DATA GPI-VM128-300

PRESSURE

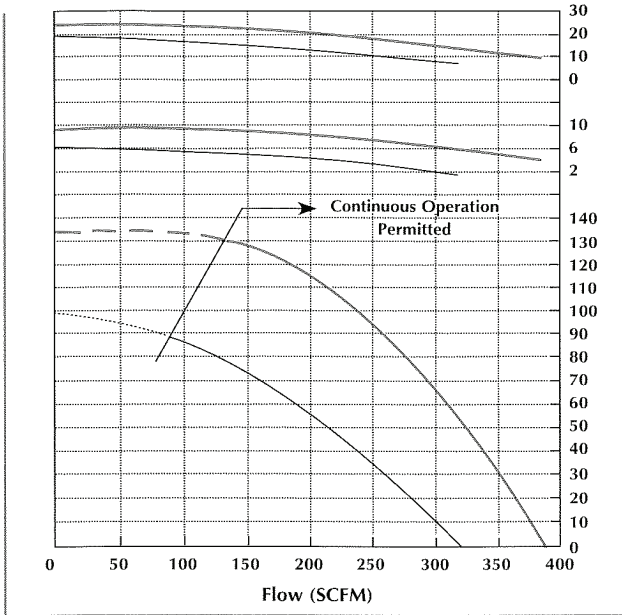

VACUUM

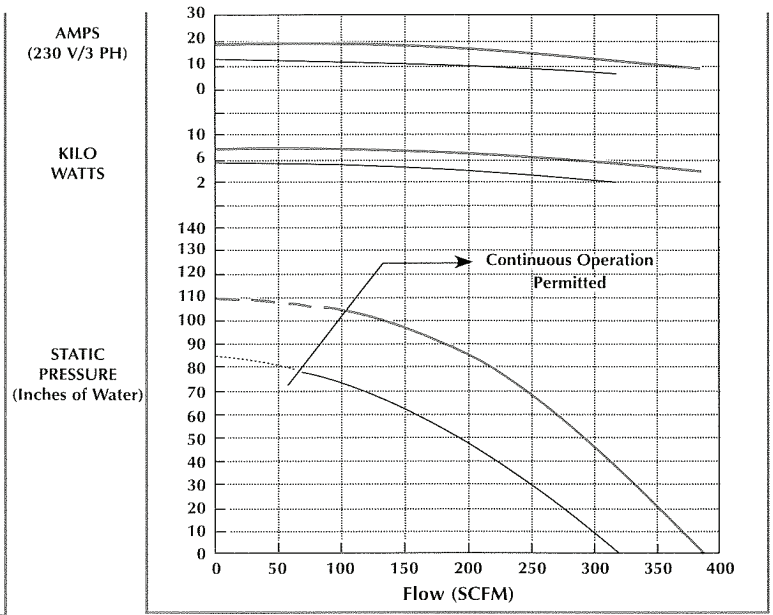

— 60 Hz
 - - - 50 Hz

TEMPERATURE RISE

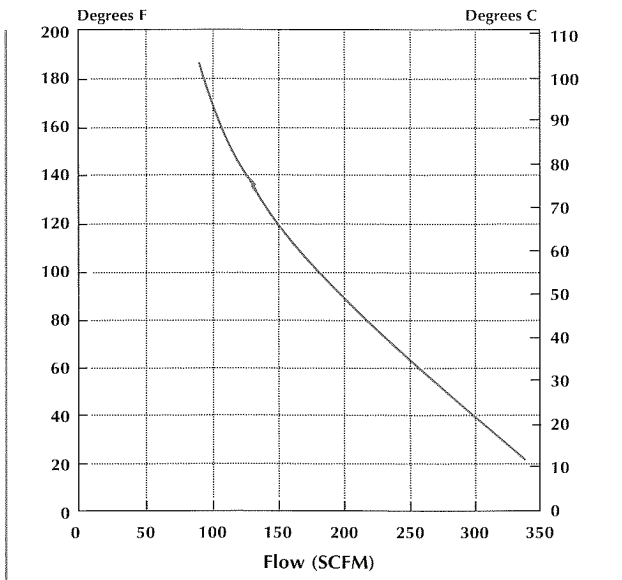

Max. Air Temperature is Value Marked • plus 40 Degrees C Ambient Temperature

SOUND LEVEL

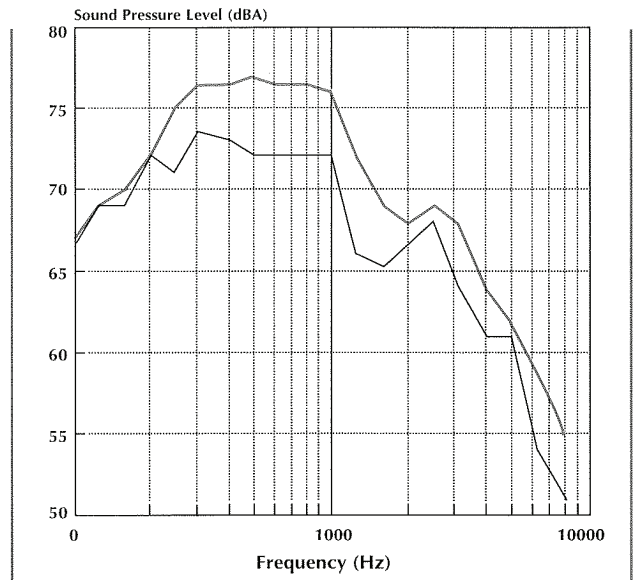

*Measured at distance of 1.0 meter

GPI-VM144-300

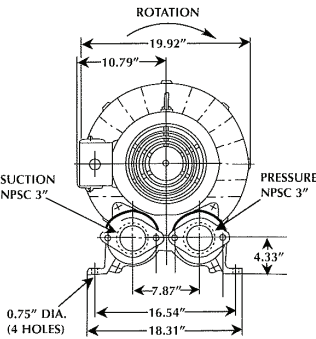
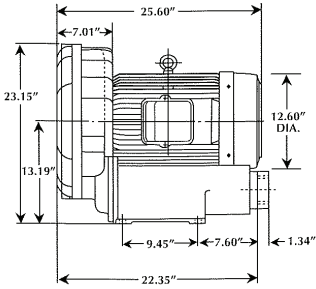

The Max-Air model GPI-VM144-300 is a single-stage ring compressor with a maximum pressure of 139 in. H₂O, a maximum vacuum of 100 in. H₂O, and a maximum capacity of 570 SCFM. It comes complete with a direct-

drive, 20 horsepower TEFC motor capable of operating on a wide range of voltages, and on 50 or 60 Hz. A pilot-duty thermal protector is standard equipment on all 3-phase models. All versions have NEMA class B insulation,

are UL recognized, CSA certified and CE. 575 Volt units are CSA certified only.

Model No.	Inlet-Outlet NPSC Ports	Hz	Voltage	Amps (Max. Rated)	Amps (Locked Rotor)	HP	Max. Pressure	Max. Vacuum	Max. Airflow	Min. Airflow	Min. Temp Rise (ΔT)	Weight	
							in. H ₂ O	in. H ₂ O	SCFM	SCFM	°F (°C)		lbs.(kg)
Low Voltage / High Voltage													
GPI-VM144A-300	3.0"	3 Phase	60	200-240/400-480	48-44/24-22	290-330/145-165	20	139	110	570	195	162 (90)	450 (205)
			50	190-230/380/460	32-28/16-14	310-350/155-175		90	75	500	140	155 (85)	
			60	575	16	130		139	110	570	195	162 (90)	

PERFORMANCE DATA GPI-VM144-300

PRESSURE

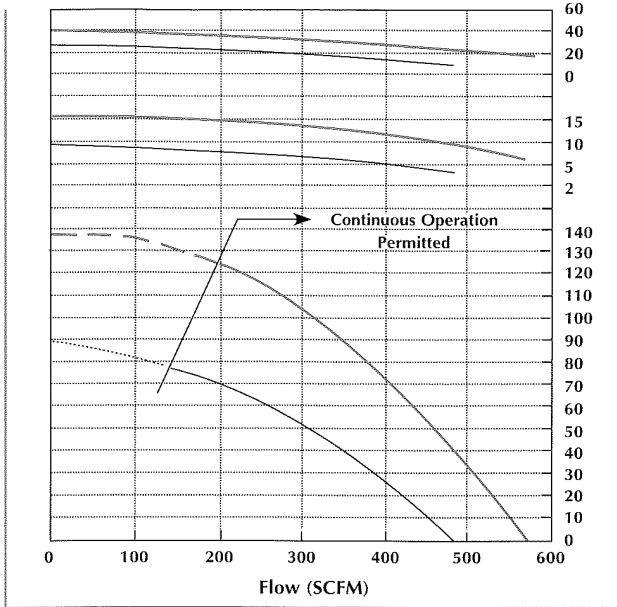

VACUUM

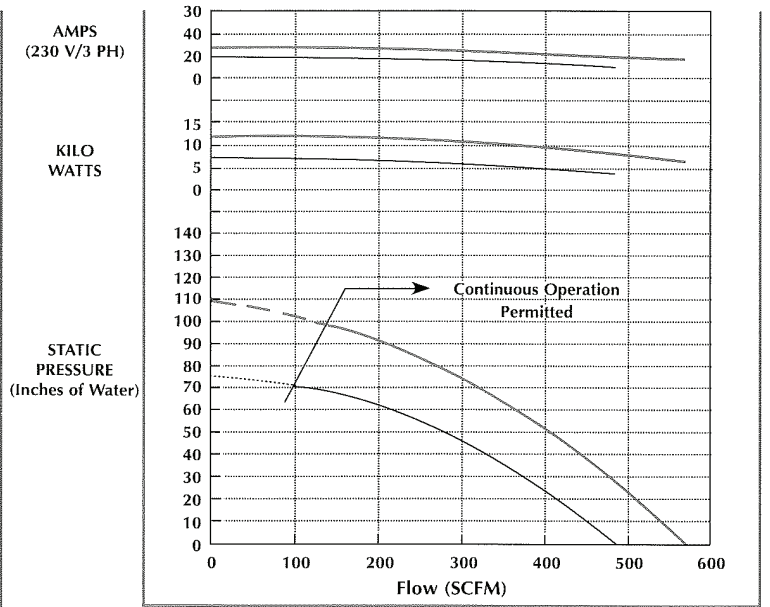

— 60 Hz
— 50 Hz

TEMPERATURE RISE

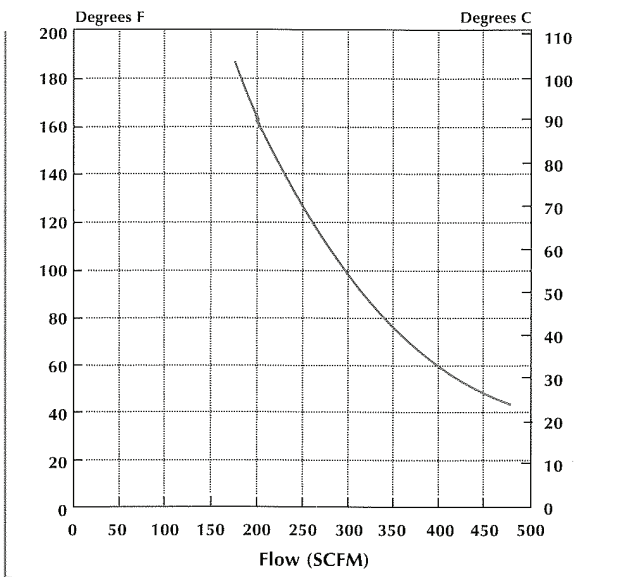

Max. Air Temperature is Value Marked • plus 40 Degrees C Ambient Temperature

SOUND LEVEL



*Measured at distance of 1.0 meter

Max-Air™ Motor Options & Accessories

Vacuum Relief ValveS

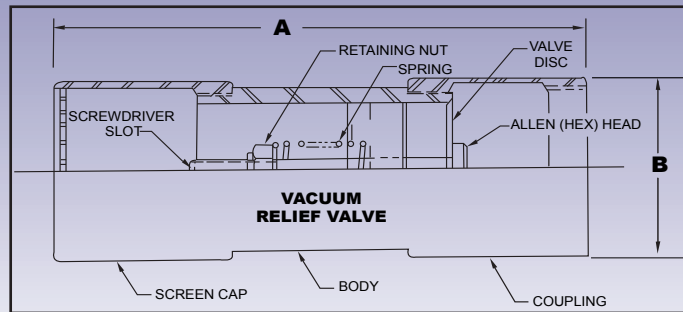
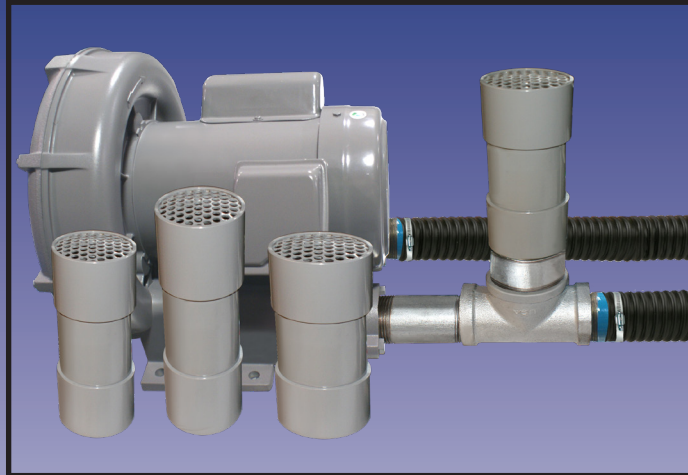

The G.P.I. vacuum relief valves are designed to protect the Max-Air™ vacuum motors from overheating when in a vacuum “dead-head” condition.

Valves are preset to provide protection for each vacuum motor, or, valves are adjustable to provide down to approximately 65% “dead- head” vacuum. Valves for models GPI-48-VM, GPI-64-VM and GPI-80-VM are 1-1/2" NPT size. Valves for models GPI-96A-VM, GPI-112A-VM and GPI-128A are 2" NPT. Model GPI-144A-VM valves are 2-1/2" NPT.

To adjust vacuum relief valve, remove screen cap, hold retaining nut or Allen (hex) head with 1/2" wrench and turn stud with screwdriver. It is recommended that a vacuum gauge be used to make accurate adjustments.

MODEL	FITS MOTOR	FACTORY SET H2O	ADJUSTMENT RANGE	A (DIAGRAM)	B (DIAGRAM)
GPI-48-VRV	GPI-48-VM	39"	39" TO 25"	6-1/4"	1-1/2" NPT
GPI-64-VRV	GPI-64-VM	42"	42" TO 27"	6-1/4"	1-1/2" NPT
GPI-80-VRV	GPI-80-VM	60"	60" TO 39"	6-1/4"	1-1/2" NPT
GPI-96-VRV	GPI-96A-VM	86"	86" TO 55"	6-1/4"	2" NPT
GPI-112-VRV	GPI-112A-VM	85"	85" TO 56"	6-1/4"	2" NPT
GPI-128-VRV	GPI-128A-VM	100"	100" TO 65"	6-1/4"	2" NPT
GPI-144-VRV	GPI-144A-VM	97"	97" TO 75"	9-3/8"	2-1/2" NPT

Max-Air™ Motor Options & Accessories

Exhaust Silencers

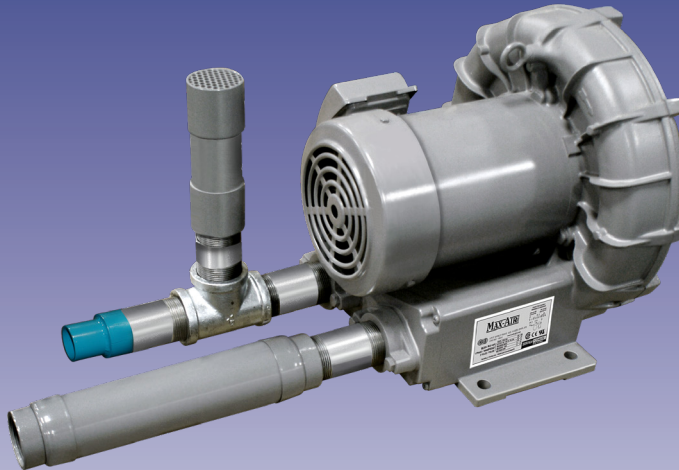

Max-Air model GPI-80-VM
with Relief Valve and
Exhaust Silencer

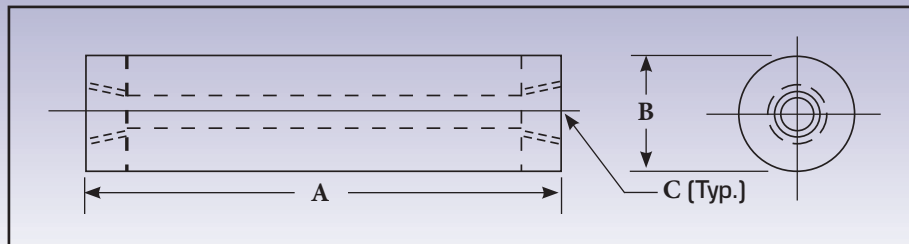

Although the Max-Air™ motors are very quiet during operation, there are times when an additional exhaust silencer may be needed. These silencers allow quieter operation of the motors in environments where noise levels are critical. The exhaust silencer reduces noise level by approximately five(5) dBA.

EXHAUST SILENCER MODEL	FITS MOTOR	A DIMENSION	B DIMENSION	C DIMENSION
GPI-48-VFY	GPI-48-VM	12" (30.48 cm)	2-1/2" (6.35 CM) NPT	1" (2.54 cm)
GPI-64-VFY	GPI-64-VM	12" (30.48 cm)	2-1/2" (6.35 CM) NPT	1.25" (3.175 cm)
GPI-80-VFY	GPI-80-VM	12" (30.48 cm)	3" (7.6 CM) NPT	1.5" (3.8 cm)
GPI-96A-VFY	GPI-96A-VM	15.75" (40 CM)	3" (7.6 CM) NPT	1.5" (3.8 cm)
GPI-112A-VFY	GPI-112A-VM	15.75" (40 CM)	3.5" (7.6 CM) NPT	2" (5 cm)
GPI-128A-VFY	GPI-128A-VM	21" (53.34 cm)	4.5" (11.4 CM) NPT	2.5" (6.35 cm)
GPI-144A-VFY	GPI-144A-VM	26" (66 cm)	5" (12.7 CM) NPT	3" (7.6 cm)

Max-Air™ Motor Options & Accessories

In-line Vacuum FilterS

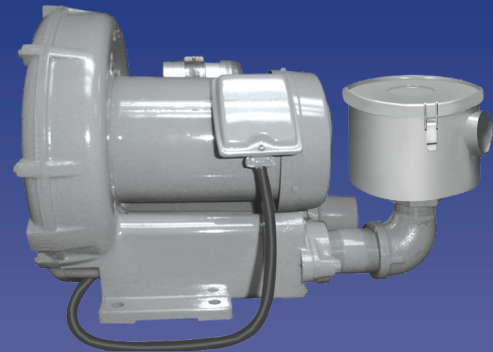
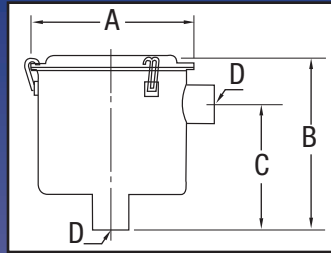

These filters are designed to protect the Max-Air™ vacuum motor by filtering the inlet air when the blower is being used for vacuum applications. A metal housing with a removable cover, retained by clamps encloses a pleated paper filter element rated for 10

micron filtration (standard). There are two types of replacement elements for the inline filter: Standard Replacement Elements and the higher quality filtration rate of the Hepa Replacement Element.

Filter Model No.	Use with Motor	A Dimension	B Dimension	C Dimension	D Dimension	Standard Replacement Element	Hepa Replacement Element
GPI-3248-VF	VM32 AND VM48	7-5/16" (18.5 CM)	6-1/2" (16.5 CM)	4-1/2" (11.4 CM)	1-1/4" (3.17 CM) FPT	GPI-3248-VFE	GPI-3248-VFEH
GPI-6480-VF	VM64 and VM80	7-5/16" (18.5 CM)	6-1/2" (16.5 CM)	4-1/2" (11.4 CM)	1-1/2" (3.8 CM) FPT	GPI-6480-VFE	GPI-3248-VFEH
GPI-96112-VF	VM96 and VM112	8-3/4" (22.2 CM)	10-1/4" (26 CM)	5-1/2" (13.9 CM)	2" (5 CM) FPT	GPI-96112-VFE	GPI-96112-VFEH
GPI-128144-VF	VM128 and VM144	14" (35.5 CM)	27-1/8" (68.8 CM)	18-1/2" (46.9 CM)	3" (7.6 CM) FPT	GPI-128144-VFE	GPI-128144-VFEH

FittingS

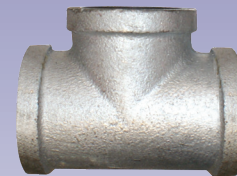
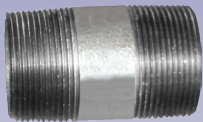

Model No.	Description	For Models
GPI-AY20TG	Galvanized Iron Tee 1-1/4" NPT - 150 psi	VM48-150-R
GPI-AY24TG	Galvanized Iron Tee 1-1/2" NPT - 150 psi	
GPI-AY2040NG	Galvanized Steel Pipe Nipple 1-1/4 X 2-1/2" Threaded Both Ends - SCH 40	VM48-150-R
GPI-AY2448NG	Galvanized Steel Pipe Nipple 1-1/2 X 3" Threaded Both Ends - SCH 40	VM128 and VM144
GPI-AY2464NG	Galvanized Steel Pipe Nipple 1-1/2 X 4" Threaded Both Ends - SCH 40	
GPI-AY2096N80	1-1/4 X 6" Length Pipe Threaded Both Ends	VM48-150
GPI-AY2420RB	1-1/2" Male X 1-1/4" Female Hex Pipe Bushing	VM48-150-R
GPI-AY1632NTOE	1" Pipe 2" Length Steel Nipple Threaded One End - SCH 40	VM32
GPI-AY2448NTOE0	1-1/2" Pipe X 3" Length Steel Nipple Threaded One End	VM64-300

SpecificationS • Options & AccessorieS

Manual Air Flow Vacuum Holddown & Blowback Systems • Page 10

Catalog No.	Description
AFMB-125M-GPI	Air Flow Vacuum/Blowback/Off System w/Manual Control Lever (1¼" I.D. AIR HOSE)
AFMB-150M-GPI	Air Flow Vacuum/Blowback/Off System w/Manual Control Lever (1½" I.D. AIR HOSE)
AFMB-175M-GPI	Air Flow Vacuum/Blowback/Off System w/Manual Control Lever (1¾" I.D. AIR HOSE)
AFMB-200M-GPI	Air Flow Vacuum/Blowback/Off System w/Manual Control Lever (2" I.D. AIR HOSE)
AFMB-300M-GPI	Air Flow Vacuum/Blowback/Off System w/Manual Control Lever (3" I.D. AIR HOSE)

Catalog No.	Description
AFM-125-GPI	Air Flow Vacuum/Off System w/Manual Control Lever (1¼" I.D. AIR HOSE)
AFM-150-GPI	Air Flow Vacuum/Off System w/Manual Control Lever (1½" I.D. AIR HOSE)
AFM-175-GPI	Air Flow Vacuum/Off System w/Manual Control Lever (1¾" I.D. AIR HOSE)
AFM-200-GPI	Air Flow Vacuum/Off System w/Manual Control Lever (2" I.D. AIR HOSE)
AFM-300-GPI	Air Flow Vacuum/Off System w/Manual Control Lever (3" I.D. AIR HOSE)

Catalog No.	Description
AFCB-125-GPI	Air Flow Vacuum/Blowback/Off System w/Manual Chain Release (1¼" I.D. AIR HOSE)
AFCB-150-GPI	Air Flow Vacuum/Blowback/Off System w/Manual Chain Release (1½" I.D. AIR HOSE)
AFCB-175-GPI	Air Flow Vacuum/Blowback/Off System w/Manual Chain Release (1¾" I.D. AIR HOSE)
AFCB-200-GPI	Air Flow Vacuum/Blowback/Off System w/Manual Chain Release (2" I.D. AIR HOSE)
AFCB-300-GPI	Air Flow Vacuum/Blowback/Off System w/Manual Chain Release (3" I.D. AIR HOSE)

Catalog No.	Description
AFC-125-GPI	Air Flow Vacuum/Off System w/Manual Chain Release (1¼" I.D. AIR HOSE)
AFC-150-GPI	Air Flow Vacuum/Off System w/Manual Chain Release (1½" I.D. AIR HOSE)
AFC-175-GPI	Air Flow Vacuum/Off System w/Manual Chain Release (1¾" I.D. AIR HOSE)
AFC-200-GPI	Air Flow Vacuum/Off System w/Manual Chain Release (2" I.D. AIR HOSE)
AFC-300-GPI	Air Flow Vacuum/Off System w/Manual Chain Release (3" I.D. AIR HOSE)

Automatic Air Flow Vacuum Holddown & Blowback Systems • Page 11

Catalog No.	Description
AFAB-125M-GPI	Air Flow Vacuum/Blowback/Off System w/Auto Release, Air Cylinder & Ft. Pedal (1¼" I.D. AIR HOSE)
AFAB-150M-GPI	Air Flow Vacuum/Blowback/Off System w/Auto Release, Air Cylinder & Ft. Pedal (1½" I.D. AIR HOSE)
AFAB-175M-GPI	Air Flow Vacuum/Blowback/Off System w/Auto Release, Air Cylinder & Ft. Pedal (1¾" I.D. AIR HOSE)
AFAB-200M-GPI	Air Flow Vacuum/Blowback/Off System w/Auto Release, Air Cylinder & Ft. Pedal (2" I.D. AIR HOSE)
AFAB-300M -GPI	Air Flow Vacuum/Blowback/Off System w/Auto Release, Air Cylinder & Ft. Pedal (3" I.D. AIR HOSE)

Catalog No.	Description
AFA-125M-GPI	Air Flow Vacuum/Off System w/Auto Release, Air Cylinder & Ft. Pedal (1¼" I.D. AIR HOSE)
AFA-150M-GPI	Air Flow Vacuum/Off System w/Auto Release, Air Cylinder & Ft. Pedal (1½" I.D. AIR HOSE)
AFA-175M-GPI	Air Flow Vacuum/Off System w/Auto Release, Air Cylinder & Ft. Pedal (1¾" I.D. AIR HOSE)
AFA-200M-GPI	Air Flow Vacuum/Off System w/Auto Release, Air Cylinder & Ft. Pedal (2" I.D. AIR HOSE)
AFA-300M-GPI	Air Flow Vacuum/Off System w/Auto Release, Air Cylinder & Ft. Pedal (3" I.D. AIR HOSE)

Available in 220 V, 1 Ph, 50 Hz; 3 Ph also available.



Specifications • Options & Accessories

Air Flow Valves • Vacuum Flow Adjustment • Page 12

Catalog No.	Description
AFV100-BV-GPI	On/Off Air Flow Valve with 1" (2.54 cm) In/Out O.D. Port
AFV100-BV-GPI	On/Off Air Flow Valve with 1.5" (3.81 cm) In/Out O.D. Port
AFV100-BV-GPI	On/Off Air Flow Valve with 1.75" (4.45 cm) In/Out O.D. Port
AFV100-BV-GPI	On/Off Air Flow Valve with 2" (5.08 cm) In/Out O.D. Port
AFV100-BV-GPI	On/Off Air Flow Valve with 3" (7.62 cm) In/Out O.D. Port

Catalog No.	Description
GPAFV-15GPI	Adjustment Valve to adjust air flow to holes in vacuum table, 1½" (3.675 cm) Port
GPAFV-134	Adjustment Valve to adjust air flow to holes in vacuum table, 1¾" (4.445 cm) Port
GPAFV-3	Adjustment Valve to adjust air flow to holes in vacuum table, 3" (7.62 cm) Port
GPAFV-3L	Adjustment Valve to adjust air flow to holes in vacuum table, 3" (7.62 cm) Port - High Volume

Flanges • Bottom Style • Page 13

Catalog No.	Description
FLB14-GPI	Table Flange Bottom Style 0.25" O.D.
FLB34-GPI	Table Flange Bottom Style 0.75" O.D.
FLB125-GPI	Table Flange Bottom Style 1.25" O.D.
FLB15-GPI	Table Flange Bottom Style 1.5" O.D.
FLB175-GPI	Table Flange Bottom Style 0.75" O.D.
FLB2-GPI	Table Flange Bottom Style 2" O.D.
FLB3-GPI	Table Flange Bottom Style 3" O.D.

Flanges • Edge Style • Page 13

Catalog No.	Description
FLE1-GPI	Table Flange Edge Style 1" O.D.
FLE15-GPI	Table Flange Edge Style 1.5" O.D.
FLE2-GPI	Table Flange Edge Style 2" O.D.

Flanges • Angled Style • Page 13

Catalog No.	Description
FLA15-GPI	Table Flange Angled Style 1.5" O.D.

Hose Connectors • Page 13

Catalog No.	Description
TEE115-GPI	Tee Connector 1.5" I.D. / 1" O.D.
TEE15-GPI	Tee Connector 1.5" I.D. / 1.5" O.D.
TEE2-GPI	Tee Connector 2" I.D. / 2" O.D.
TEE3-GPI	Tee Connector 3" I.D. / 3" O.D.
MHC4-GPI	Manifold 1.5" I.D. / 1" O.D., 4 Port Connector
MHC6-GPI	Manifold 3" I.D. / 3" O.D., 6 Port Connector
MHC7-GPI	Manifold 3" I.D. / 3" O.D., 7 Port Connector

Heavy-duty Vacuum Hoses • Page 14

Catalog No.	Description
GPIH16E	Vacuum Hose 1", Flexible Thermoplastic (Max. Hose Length - 50 Ft. (15.2 m)
GPIH150E	Vacuum Hose 1½", Flexible Thermoplastic (Max. Hose Length - 50 Ft. (15.2 m)
GPIH175E	Vacuum Hose 1¾", Flexible Thermoplastic (Max. Hose Length - 50 Ft. (15.2 m)
GPIH40E	Vacuum Hose 2½", Flexible Thermoplastic (Max. Hose Length - 50 Ft. (15.2 m)
GPIH3E	Vacuum Hose 3", Flexible Thermoplastic (Max. Hose Length - 50 Ft. (15.2 m)
GPIH4E	Vacuum Hose 4", Flexible Thermoplastic (Max. Hose Length - 25 Ft. (7.6 m)
GPIH5E	Vacuum Hose 5", Flexible Thermoplastic (Max. Hose Length - 25 Ft. (7.6 m)

Hose Clamps (Worm Drive) • Page 14

Catalog No.	Description
GPIHC34118	Vacuum Hose Clamp ¾ - 1 " (19-28 mm)
GPIHC114134	Adjustment Valve to adjust air flow to holes in vacuum table, 1¾" (4.445 cm) Port
GPIHC1122	Adjustment Valve to adjust air flow to holes in vacuum table, 3" (7.62 cm) Port
GPIHC23	Adjustment Valve to adjust air flow to holes in vacuum table, 3" (7.62 cm) Port - High Volume

Table Support Frame System

Catalog No.	Description
VB-MISC	Table Support Frame

Your vacuum table will be mounted onto this table support frame with minimal operational interruption. The table will be fitted into the support frame with cross bars. The table support frame comes complete with a vacuum motor, a vacuum/blowback assembly and detachable legs. The motor and blowback assembly will be mounted on the frame. This is a manual lever system. If necessary, you may need to relevel/shim the table. This complete system also includes enough hoses and clamps to make your table fully operational.

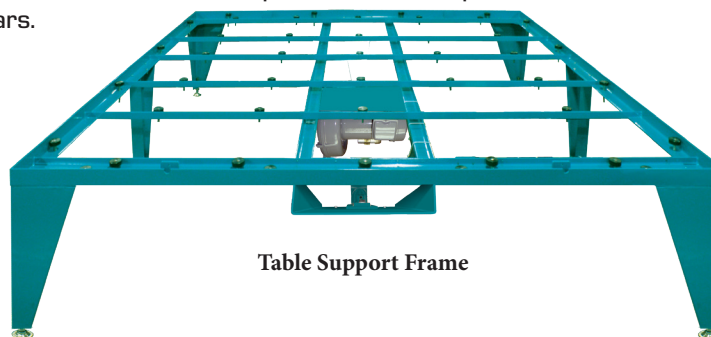

Table Support Frame

VacuumTables.com

A Division of Graphic Parts International Inc.

Your Complete Manufacturing Source for
Tables for all Industries

Vacuum

Our technical sales staff will make sure you choose the right vacuum table for your company's needs, delivering the performance you require at a cost within your budget. Industry experts in both technical support and service will walk you through the installation and setup process for maximum productivity right from the start.

WORLDWIDE DISTRIBUTION

CORPORATE HEADQUARTERS AND MANUFACTURING FACILITIES

GRAPHIC PARTS INTERNATIONAL INC.

4321 N. Knox Avenue • Chicago, IL 60641 USA

773.725.4900 • Fax: 773.777.0909

sales@vacuumtables.com • www.vacuumtables.com

